



Portfolio

PRANAV GAWDE

PRODUCT DESIGNER | MECHANICAL ENGINEER | STARTUP CONSULTANT



DESIGN VISION

A clear vision anchors strategic decisions and drives purposeful innovation. My design philosophy is guided by two defining principles:

Meaningful Design - Sustainability as Strategy

I view design as a long-term responsibility. Products and services must extend beyond immediate utility to create enduring value for both business and society. By integrating circular thinking, manufacturability, and commercial viability into the design process, I aim to develop solutions that are strategically sound, environmentally conscious, and built for real-world impact.

Minimalist Design - Clarity Through Purpose

I believe the strongest solutions emerge from clarity and disciplined restraint. For me, “less is more” represents intentional design eliminating unnecessary complexity to focus on core functionality and meaningful user experience. I strive to create products that are intuitive, efficient, and purpose-driven, where every element exists for a reason.



CONTENT OVERVIEW



Startup Consultancies

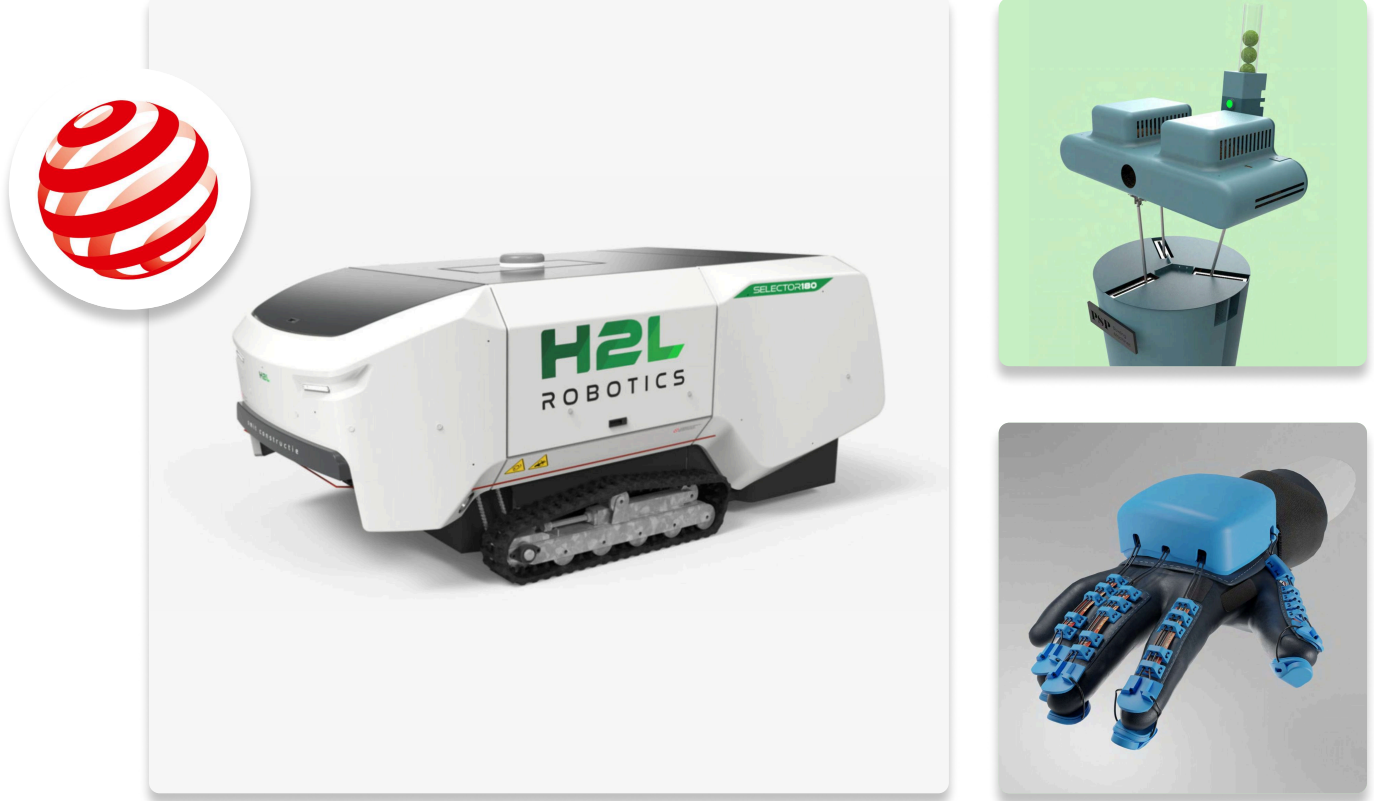

Engineering Design & Tech

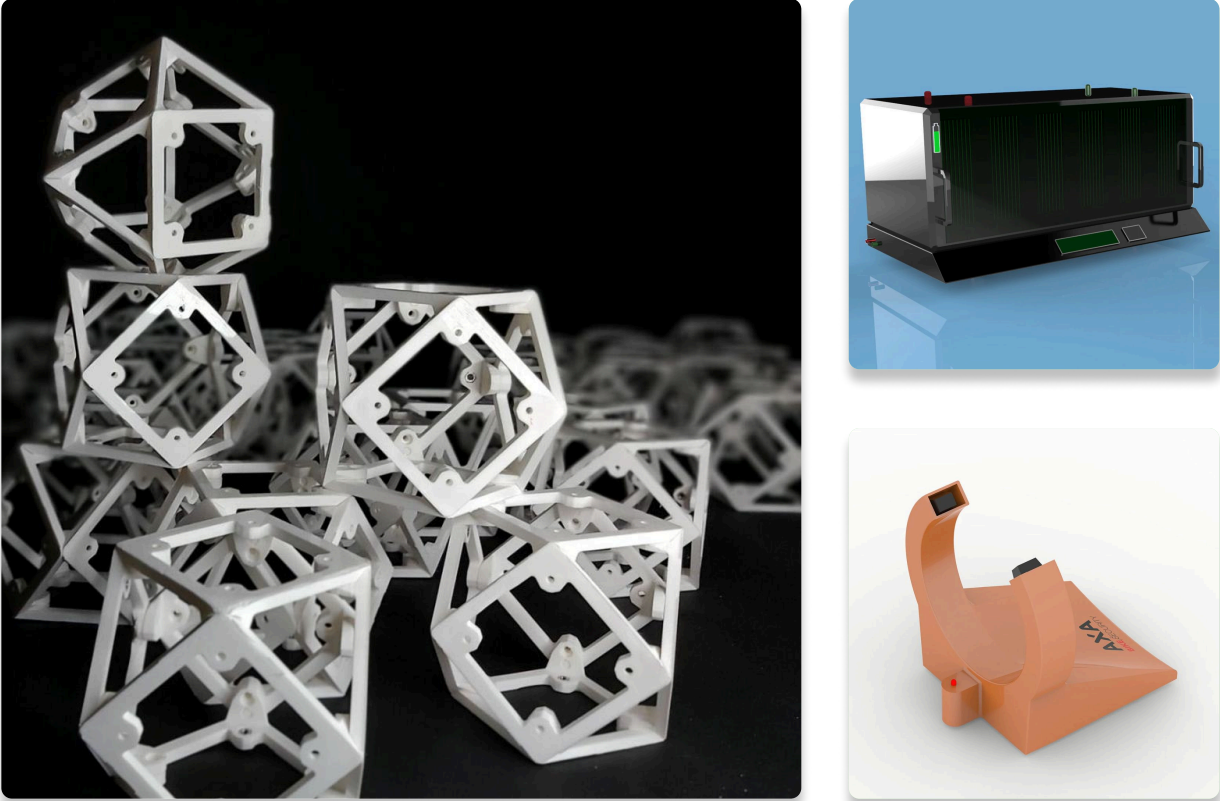

Design & Research



STARTUP LIAISON & CONSULTANCIES

Startup mentorship and design consultancy supporting early-stage ventures in developing manufacturable, market-ready products through design, prototyping, and strategic product development.

 Design & Innovation Lead

 riidl Foundation, Technology Business Incubator, Mumbai



+58 more Early-stage startups

Lead the program supporting early-stage entrepreneurs from idea to MVP, guiding problem validation, concept development, prototyping, and MVP design.

 Apr 2024 - May 2026



+18 more Pvt. Ltd. Ventures

Served as liaison and design consultant for Pvt. Ltd. Ventures, guiding hardware design, manufacturing readiness, and supply chain strategy.

 Aug 2022 - Mar 2024

GRobo

Consulted on the redesign and iterative development of the ROBO, improving technical capabilities, body design, and manufacturability through DFM/DFA principles.

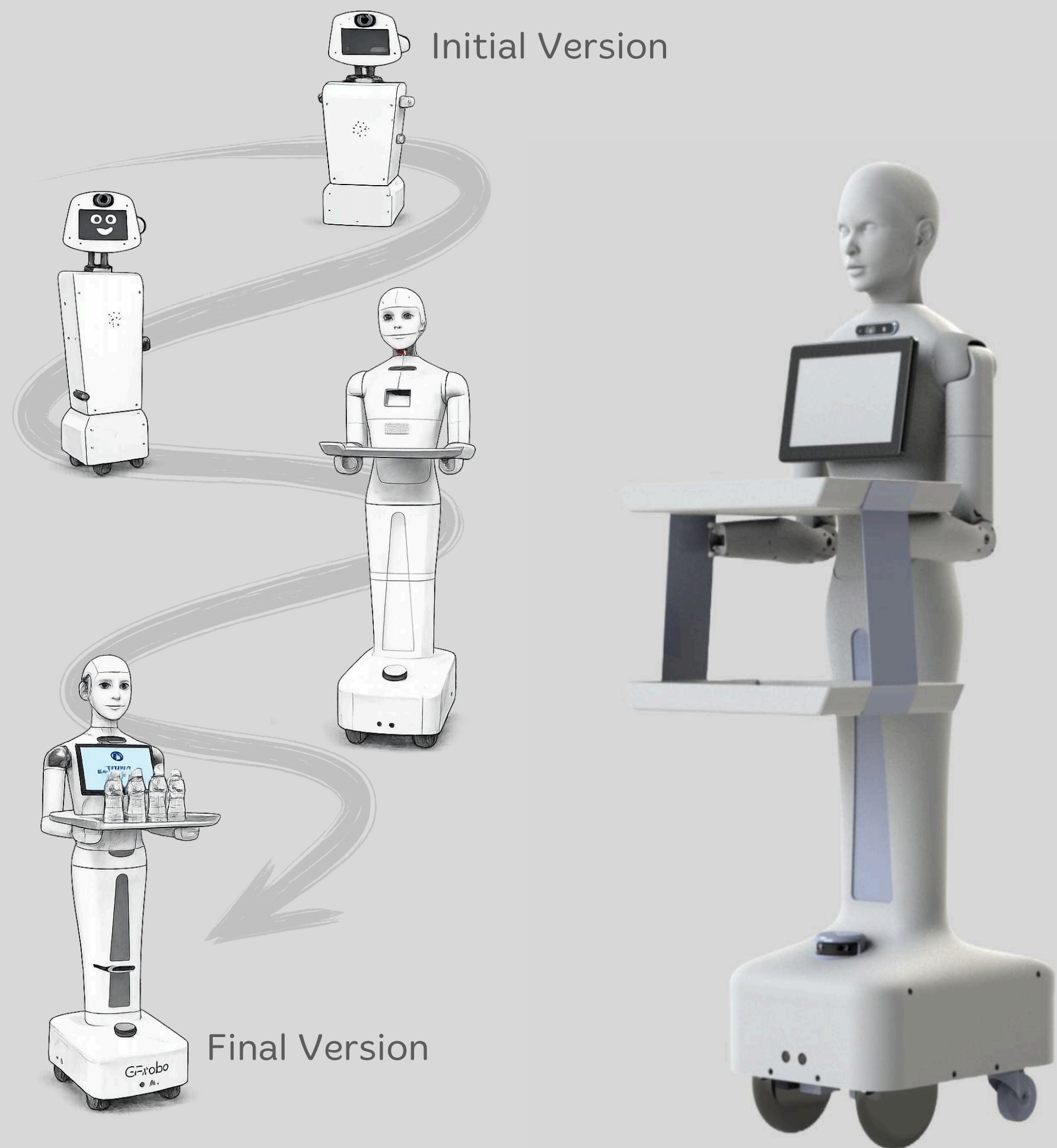

FSTRIDE

Guided Fostride's product evolution from a B2B waste segregation system to an AI-powered smart bin (R3Bin) through multiple design and technology iterations.



The smart bin (R3Bin) is shown with several key features highlighted in callout boxes:

- AI Vision**: 50k+ Training Set
- IoT Sensors**: Real-time monitoring
- Analytics**: Live dashboard
- Eco Impact**: Track carbon savings
- AI-Powered**
- Enterprise Ready**

Human Biogenesis

Consulted on the product and packaging design of the SD Kit for Human Biogenesis, developing a patentable body design enhancing usability, visual identity, & market readiness.

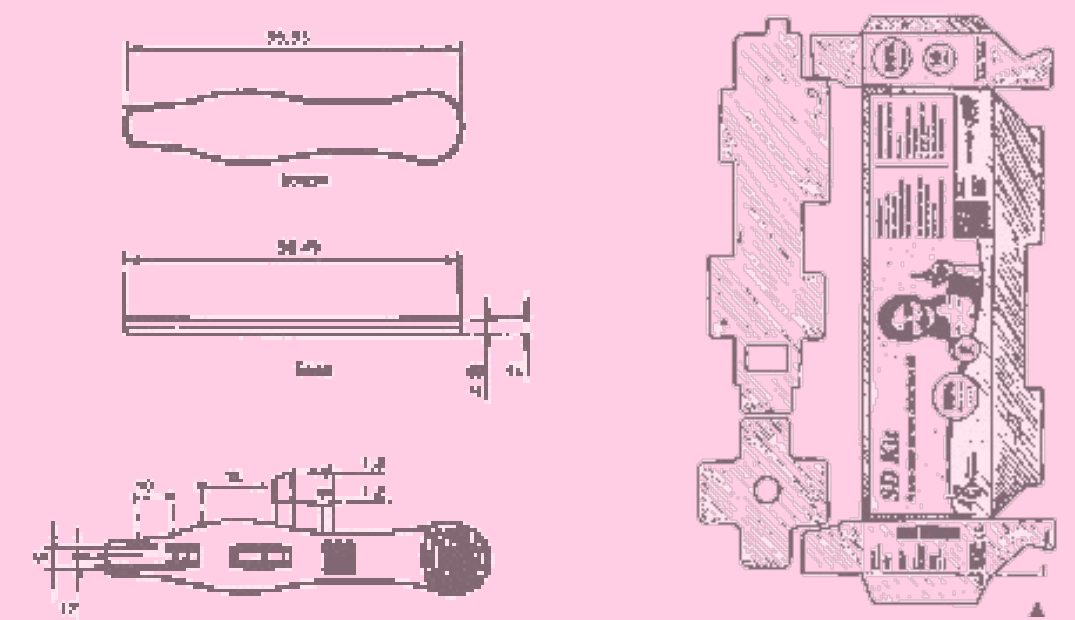



Supported Prevalent Automotives Pvt. Ltd as incubation liaison, mentoring the development of a 200 kg payload electric cargo moped for scalable delivery applications.

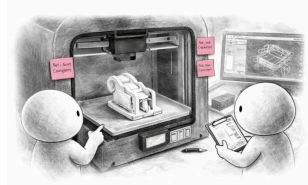

Rapid Prototyping



Design for Manf/Assembly

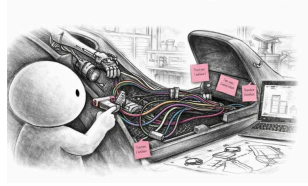

Electrical routings & wirings



Supported Ayka Control Systems as incubation liaison, driving business development and visual communication, contributing to their recent ₹1 crore fundraise.

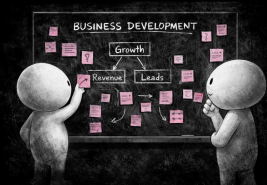

Business Development



Visual communication



Photo/video shoots and renders

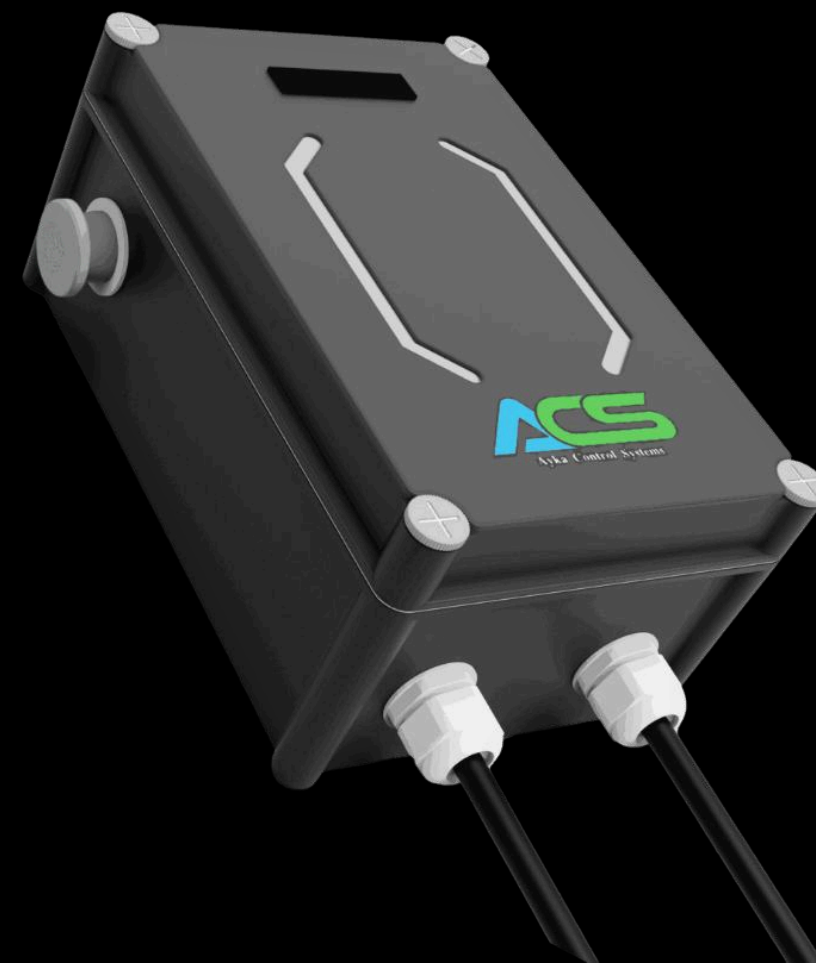

Mentored and consulted Transtrak on ergonomic seat design, user research, and fundraising strategy, supporting product development and venture growth.



Ergonomic Seat Redesign



User Experience Research & Design



Fund raising and business development

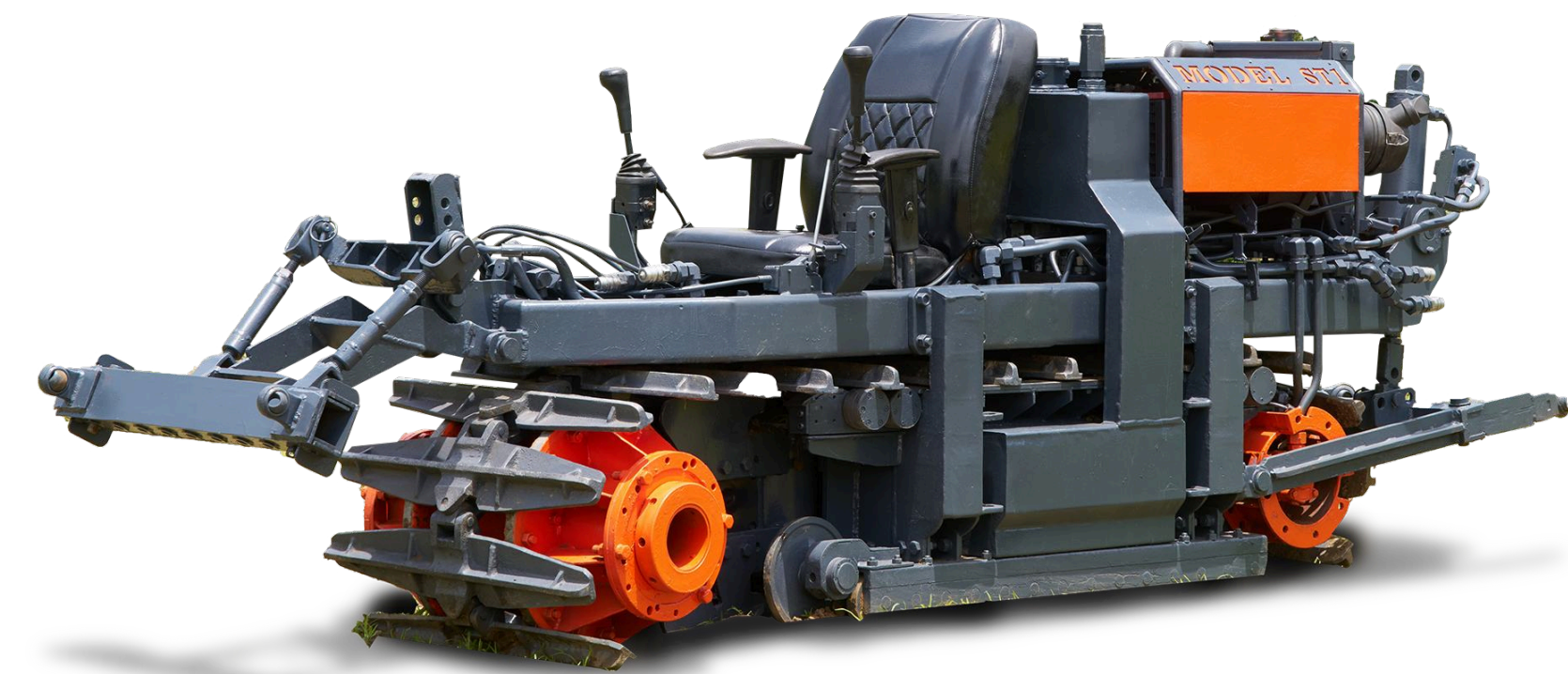



Consulted Eva Scalp Cooling Devices (Stemtech Pvt. Ltd.), supporting visual communication and product presentation; contributing to funding secured through Shark Tank India.



Mentored and served as liaison for Strictly Electric Pvt. Ltd. over two years, supporting product development and redesign focused on form, aesthetics, and manufacturability.

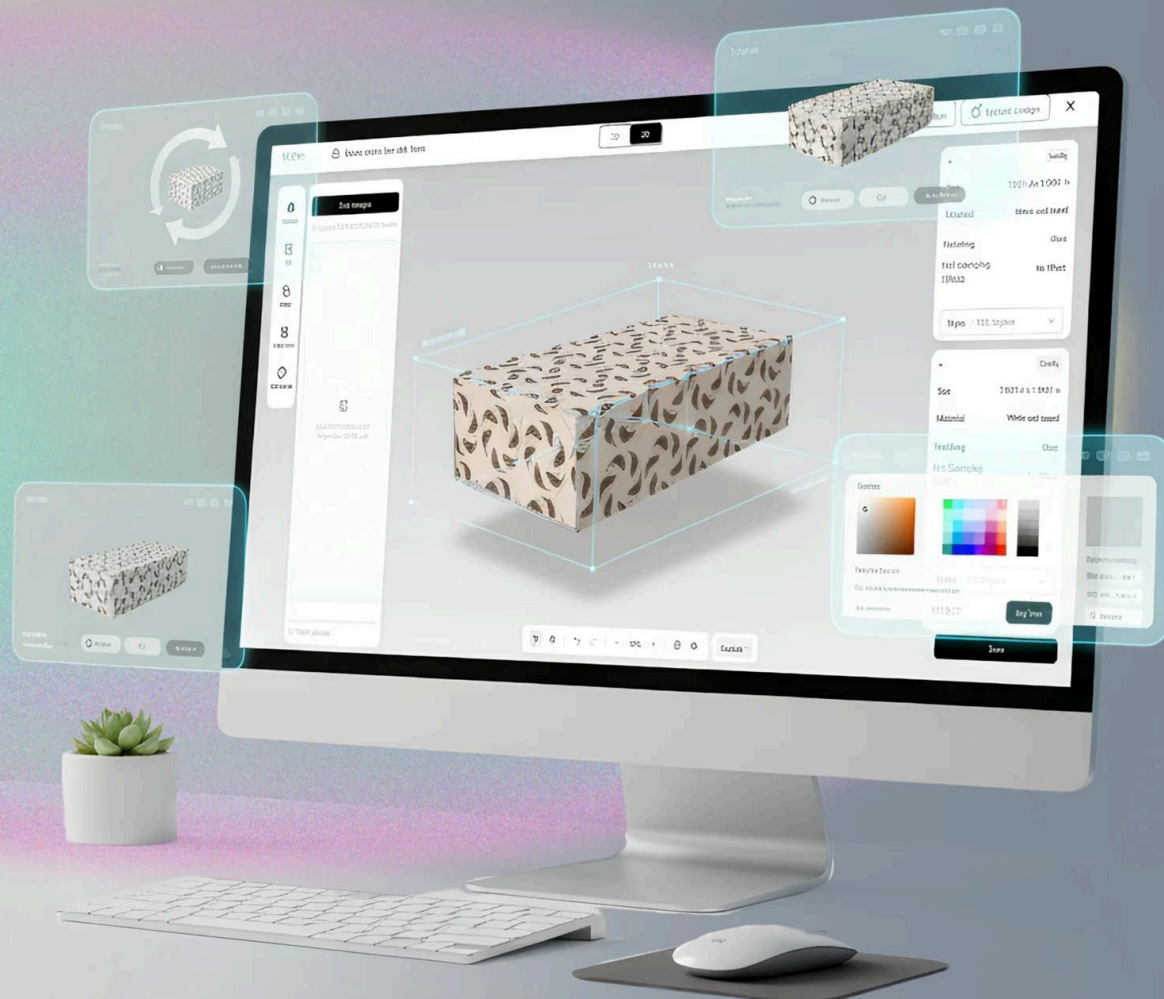

Mentored and served as liaison for Ezpac (Pacmania Solutions Pvt. Ltd.) over two years, supporting business development, fundraising, and packaging design; contributing to their feature on Shark Tank India.



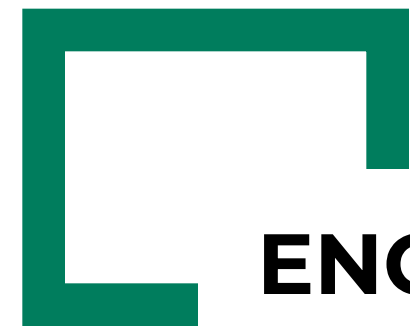

ENGINEERING DESIGN & TECH

Engineering and robotics projects for real companies and startups, where I contributed to designing and developing technology products from concept and prototyping to commercialization.



H2L Robotics B.V.
Designer & Production Manager

📍 Schagen, Netherlands

📅 July 2020 - June 2022



SenseGlove B.V.
Product Designer

📍 Delft, Netherlands

📅 Jan 2020 - June 2020

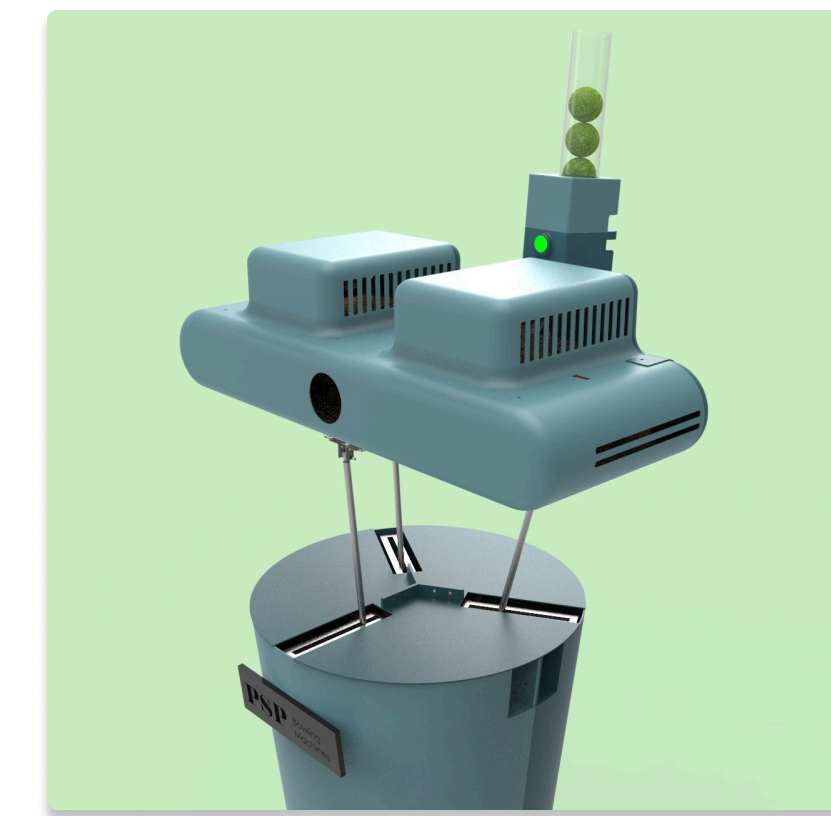

PSP Bowling Machines
Co-founder & Design Engg

📍 Mumbai, India

📅 July 2017 - June 2019

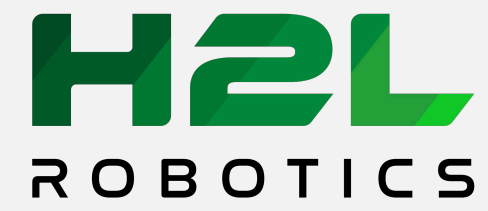

Worked with H2L Robotics (Netherlands) as Designer and Production Manager, co-designing, manufacturing, and commercialising the Selector 180 - an autonomous tulip selection robot - contributing to system design, production workflows, assembly, wiring integration, and field deployment.



Red Dot Design Award Winner 2022



Product, Systems, and Control Panel Design

Led the design and development of product body components and translated the complete system into detailed CAD models, iterating and validating designs for mechanical mechanisms, manufacturing processes, electrical wiring conduits, and control panels to achieve a robust and deployable system.

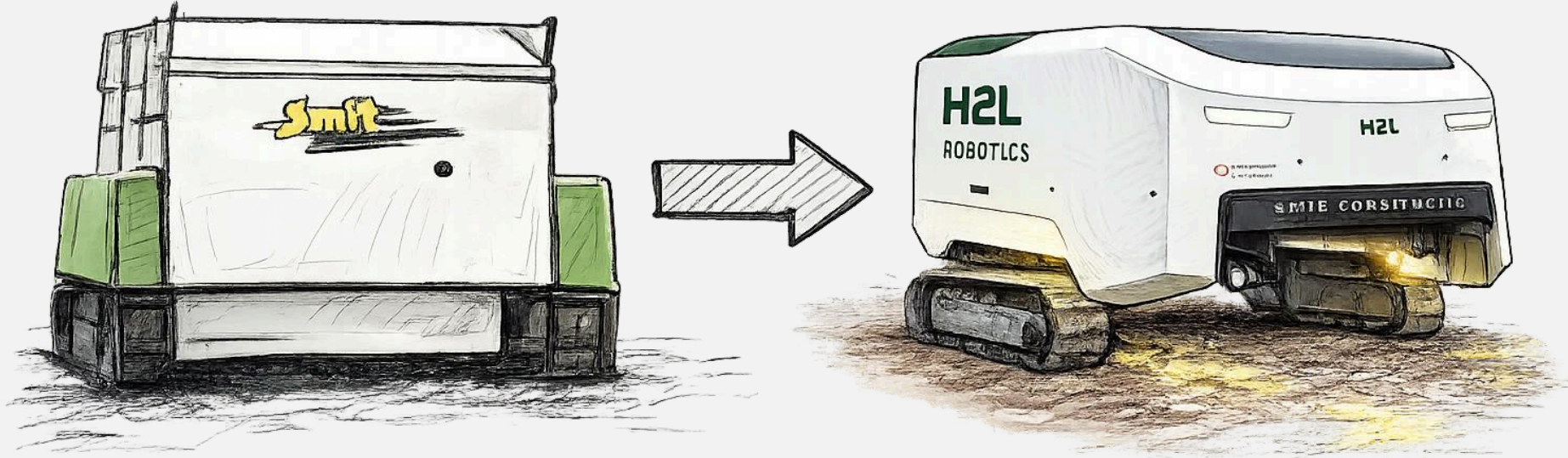

2019-20

2021-22

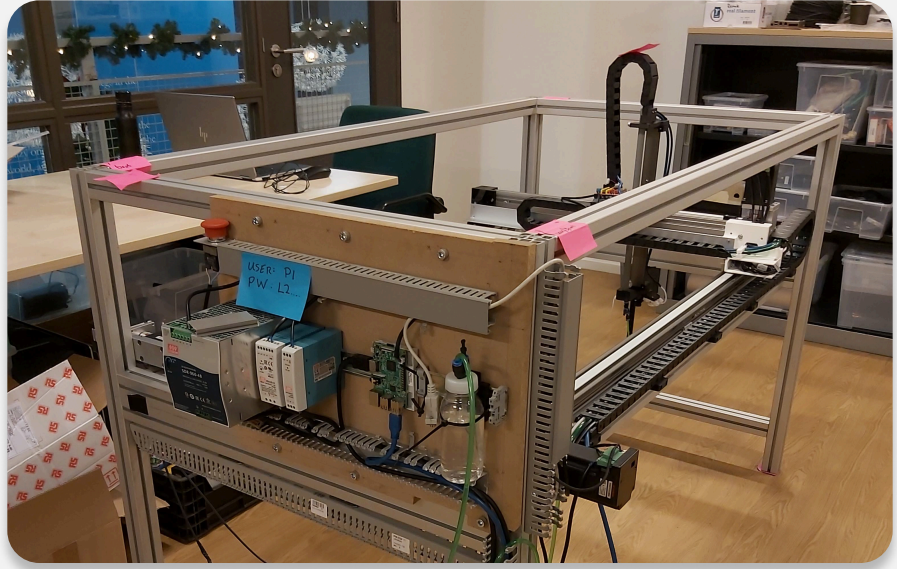
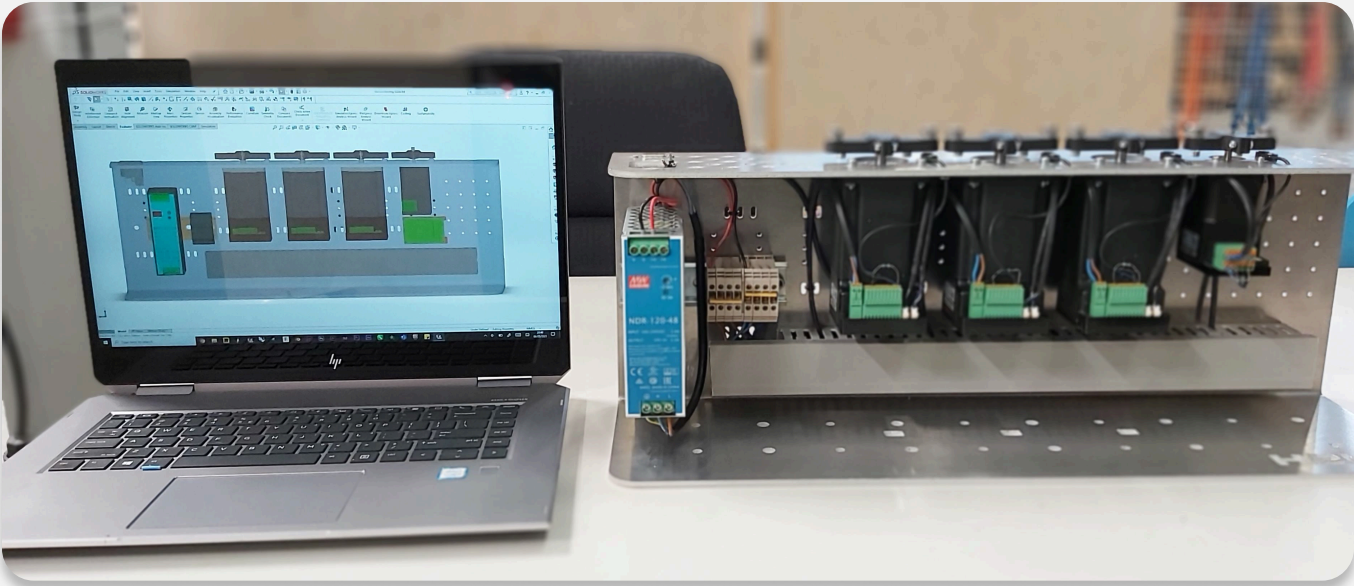
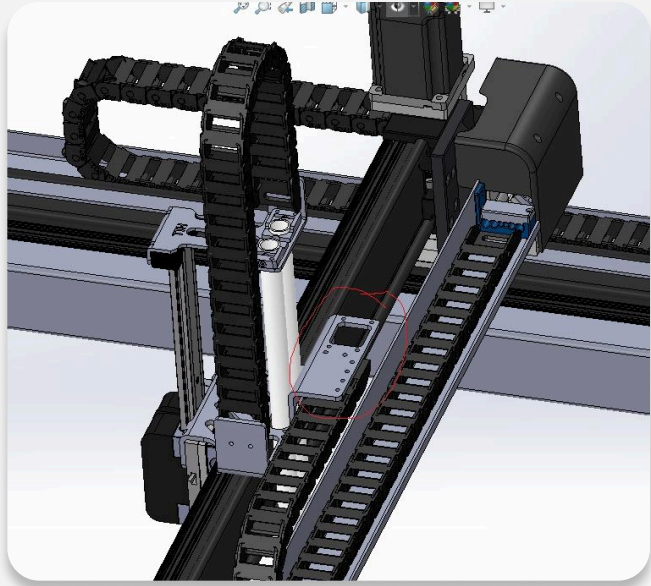
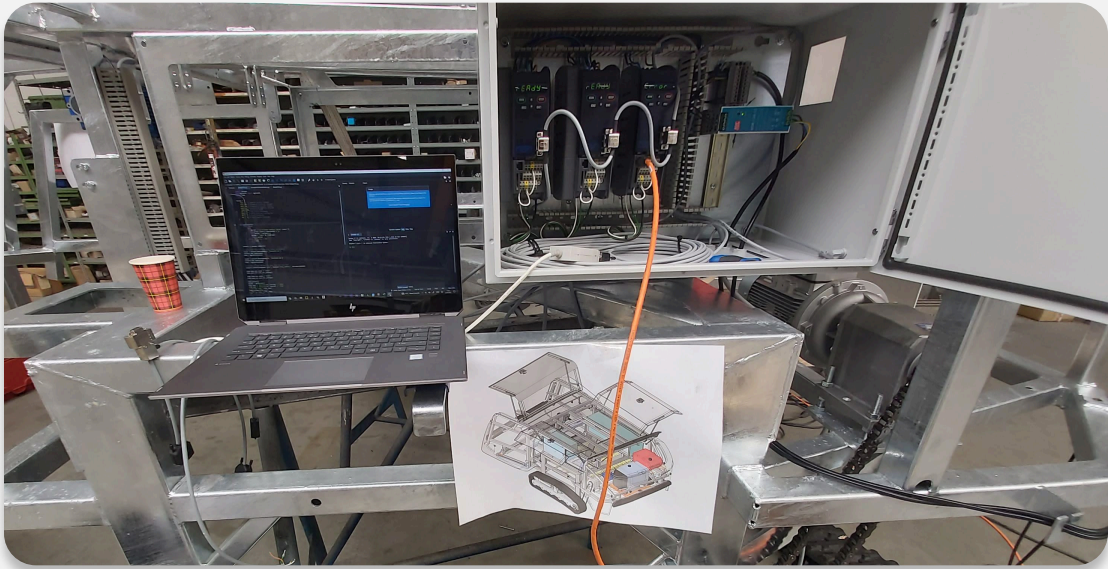
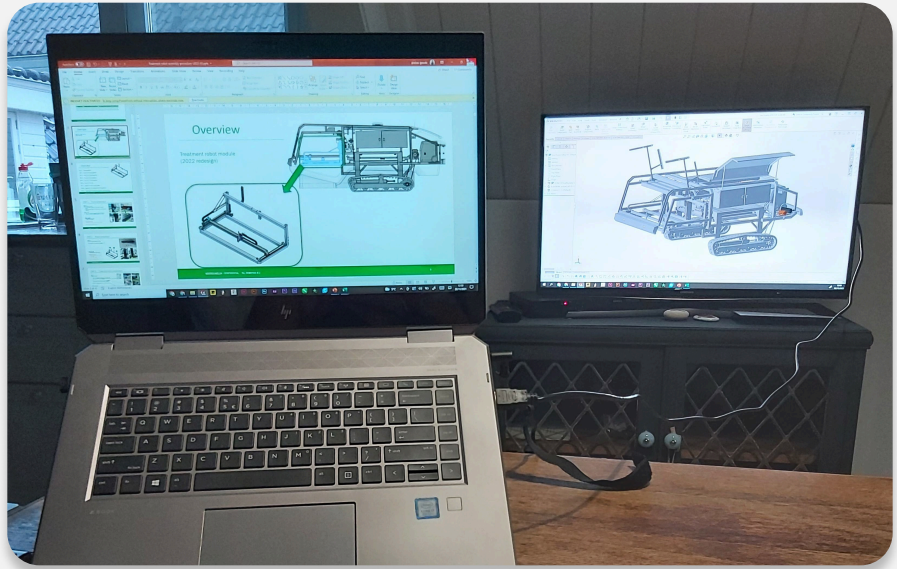

Production & Supply Chain Management

Managed production and supply chain operations as project lead, structuring the complete BOM using Philips' 12NC system, overseeing inventory and global sourcing, and planning and executing production over two consecutive years, delivering a cumulative output of 16 happy customers.





Sense Glove

Product design project at SenseGlove (Netherlands) focused on the embodiment design of a next-generation haptic VR glove, translating functional principles and design challenges into a validated working prototype called the Manao Glove.

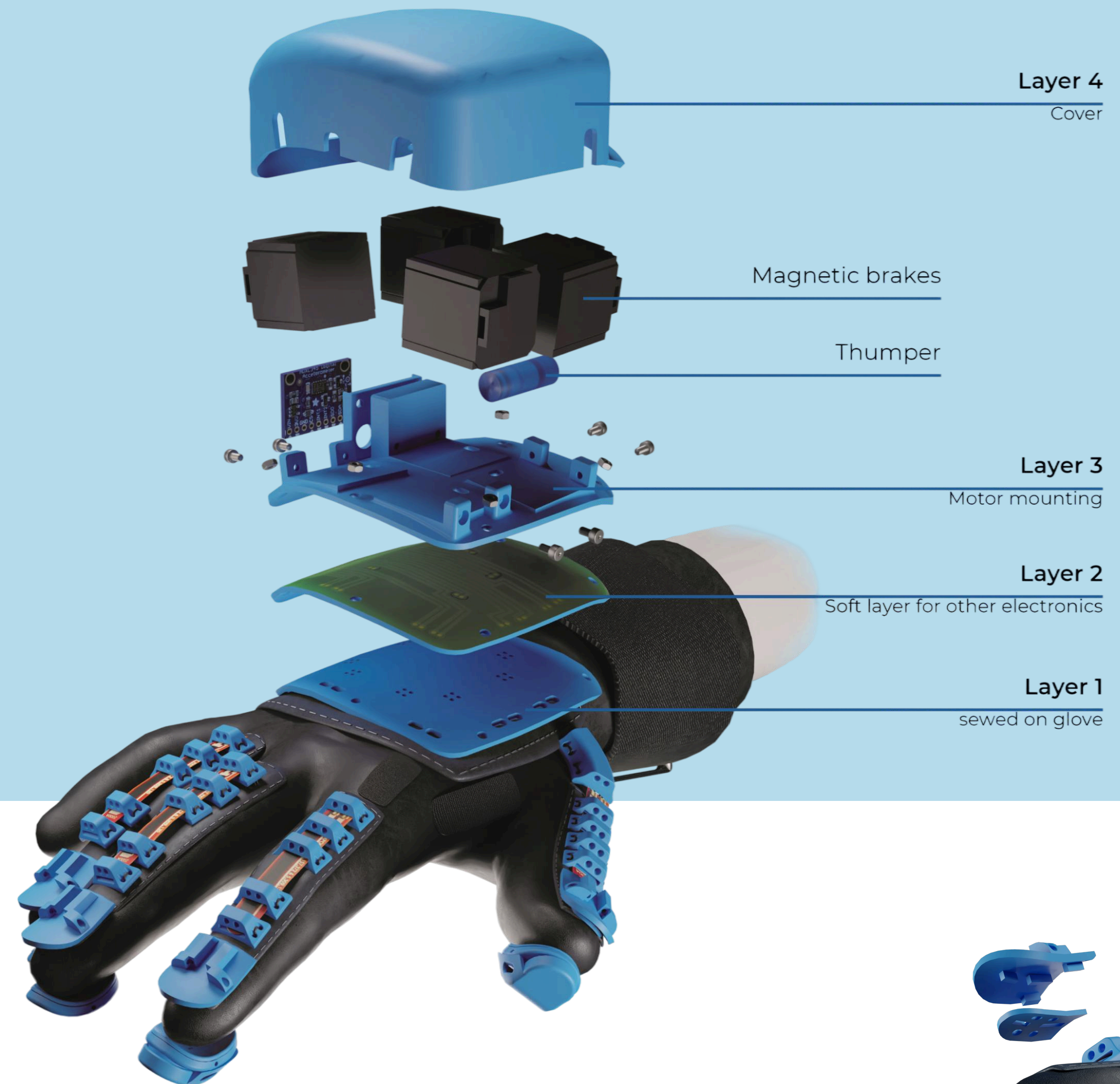

Flex Sensor

Haptic Motor



Design Sprints

Structured the 6-month project through design sprints across key subsystems, including thimble and cable guides, force feedback mechanism with frame, and soft glove design, with multiple iterations and user testing.

Sketches & Visualisations

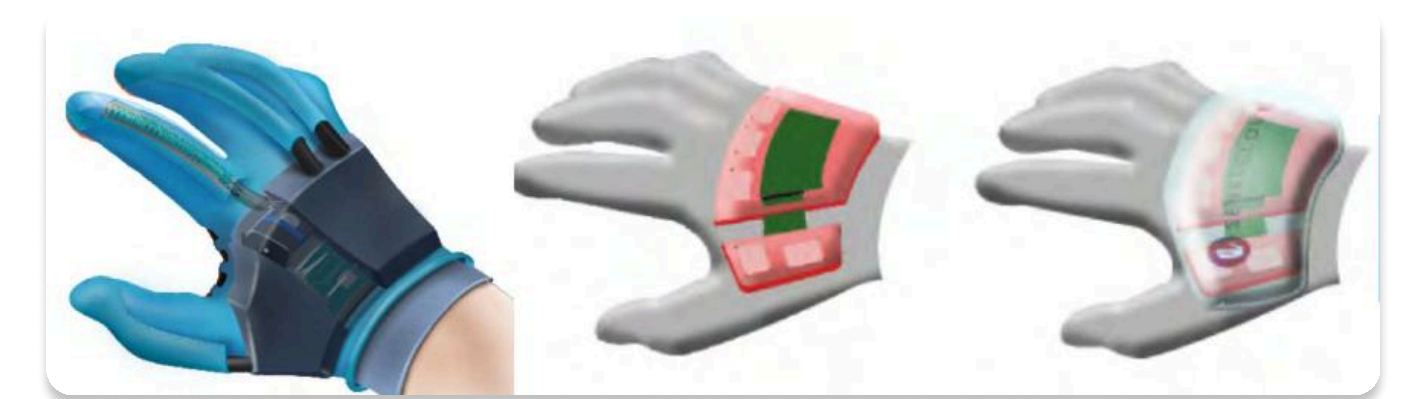
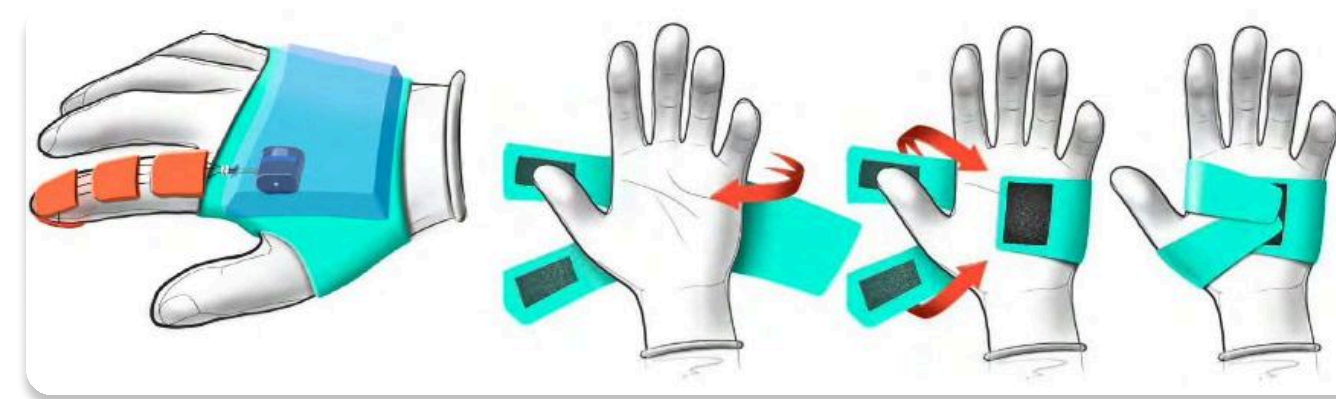
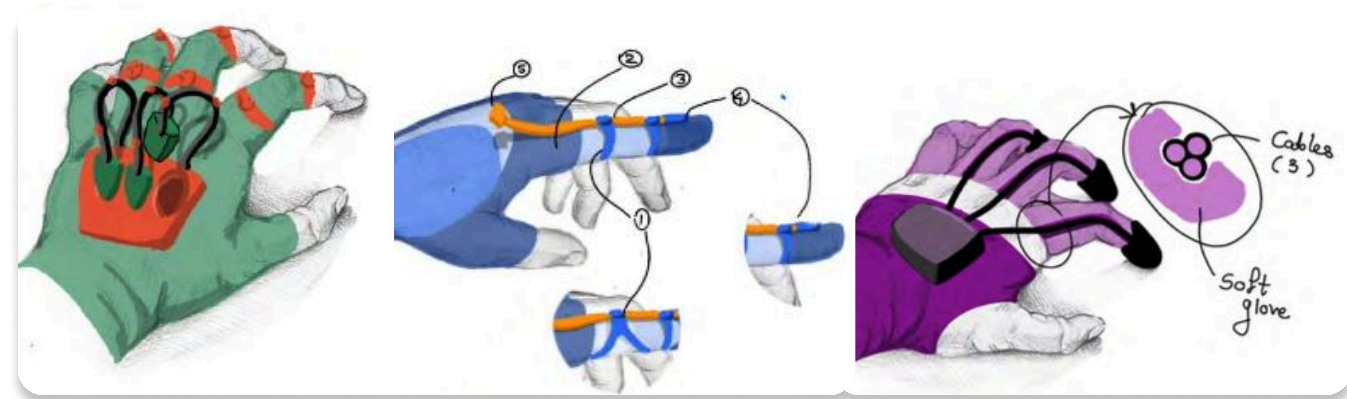

Low-Fidelity Prototypes

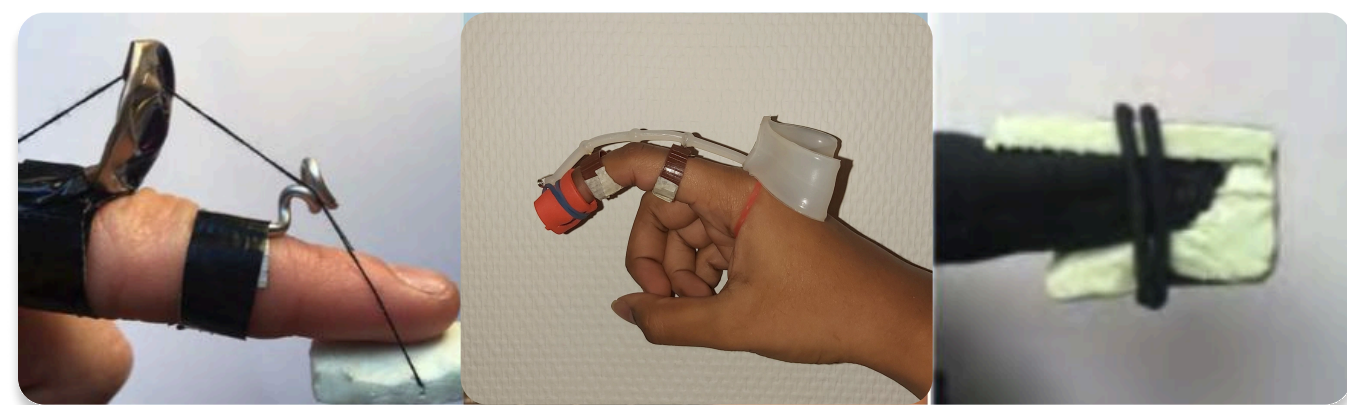

High-Fidelity Prototypes

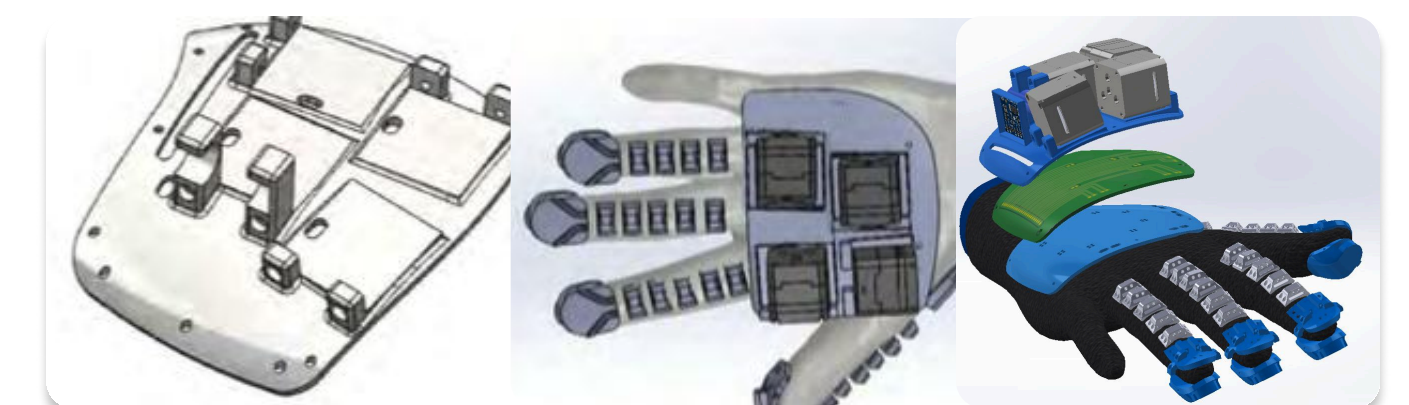
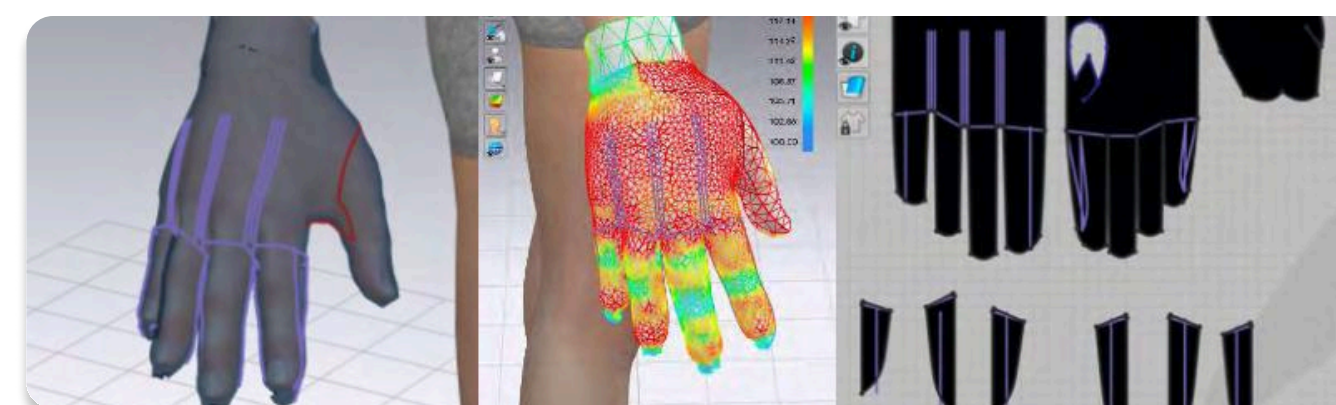



Product Comparison & Human Interaction

Executed VR-based product benchmarking using Blender Game Engine simulations, assessing SenseGlove and Manao glove performance in Industry 4.0 tasks such as screw tightening, object manipulation, and haptic feedback.

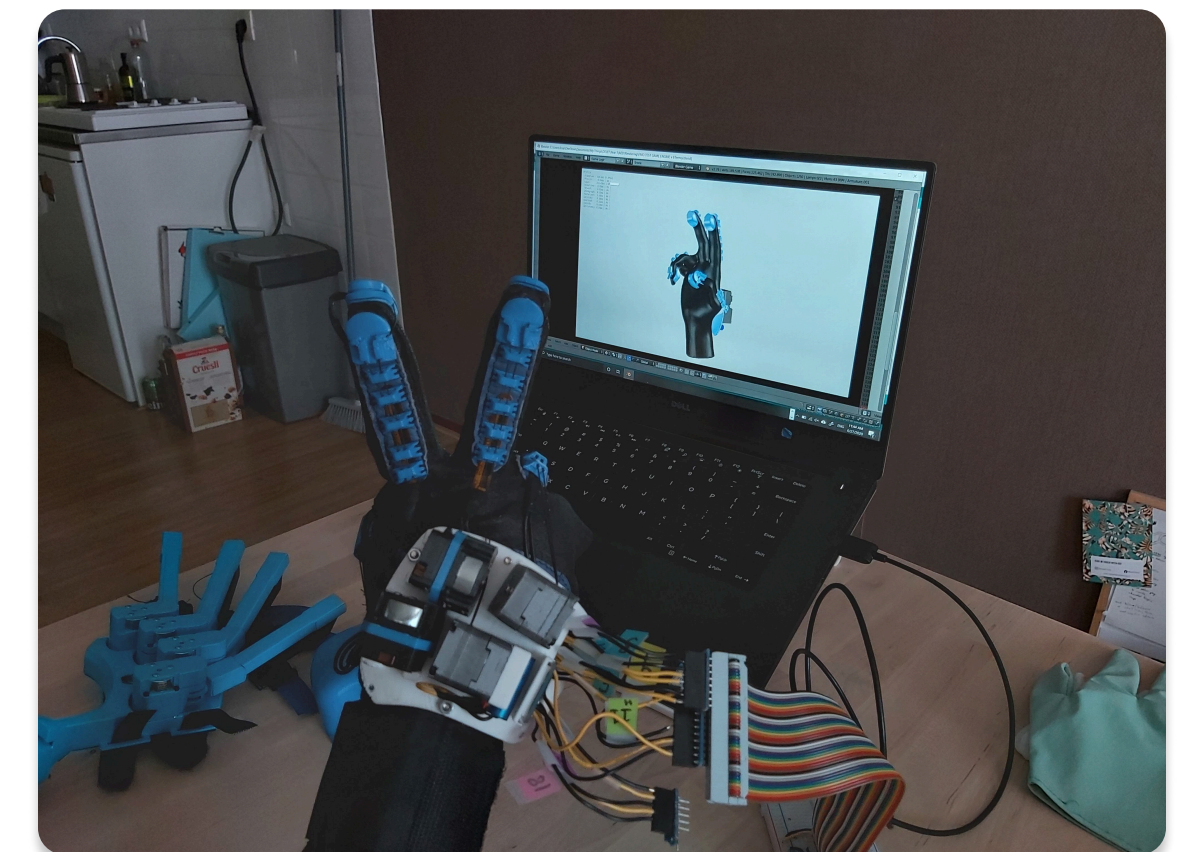

PSP

Bowling Machines

Co-founded PSP Bowling Machines with two partners, developing an autonomous cricket bowling system designed for precise and repeatable training. The machine enables control over line, length, and delivery height, simulating real match conditions for both professional and recreational players.

Built on a patent-oriented mechanism with 3 rotational and 1 translational degrees of freedom, the system can replicate diverse bowling styles—including pace, swing, spin, and varying release heights—offering a versatile and realistic training solution.

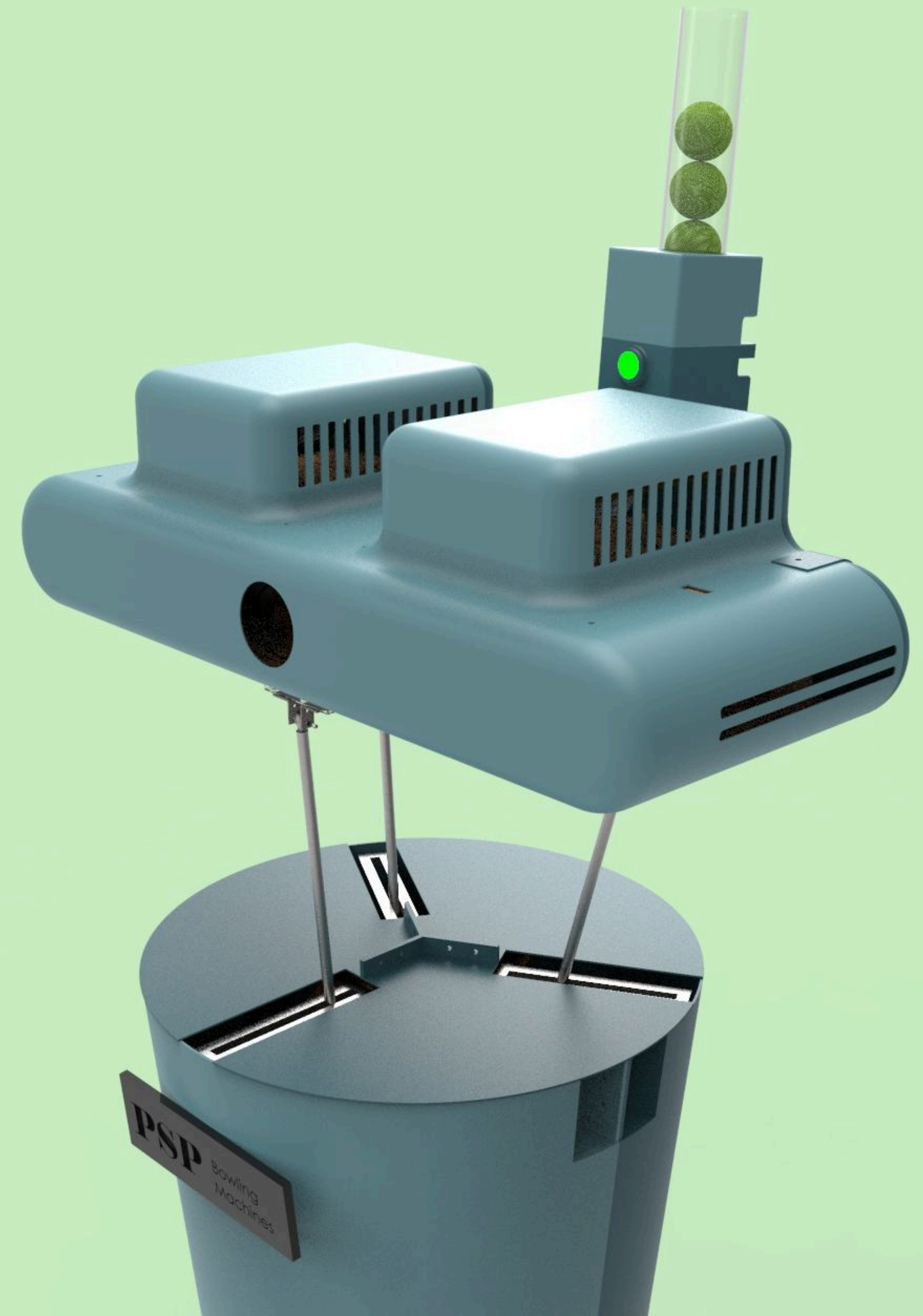
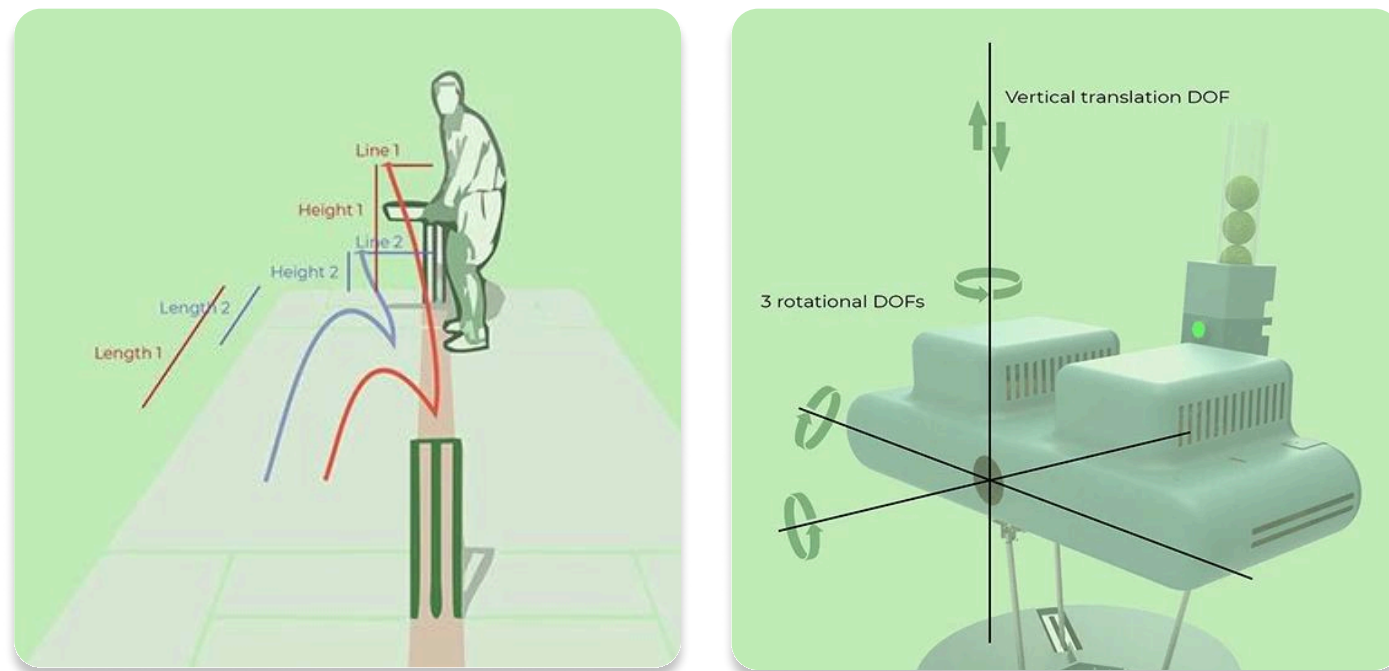

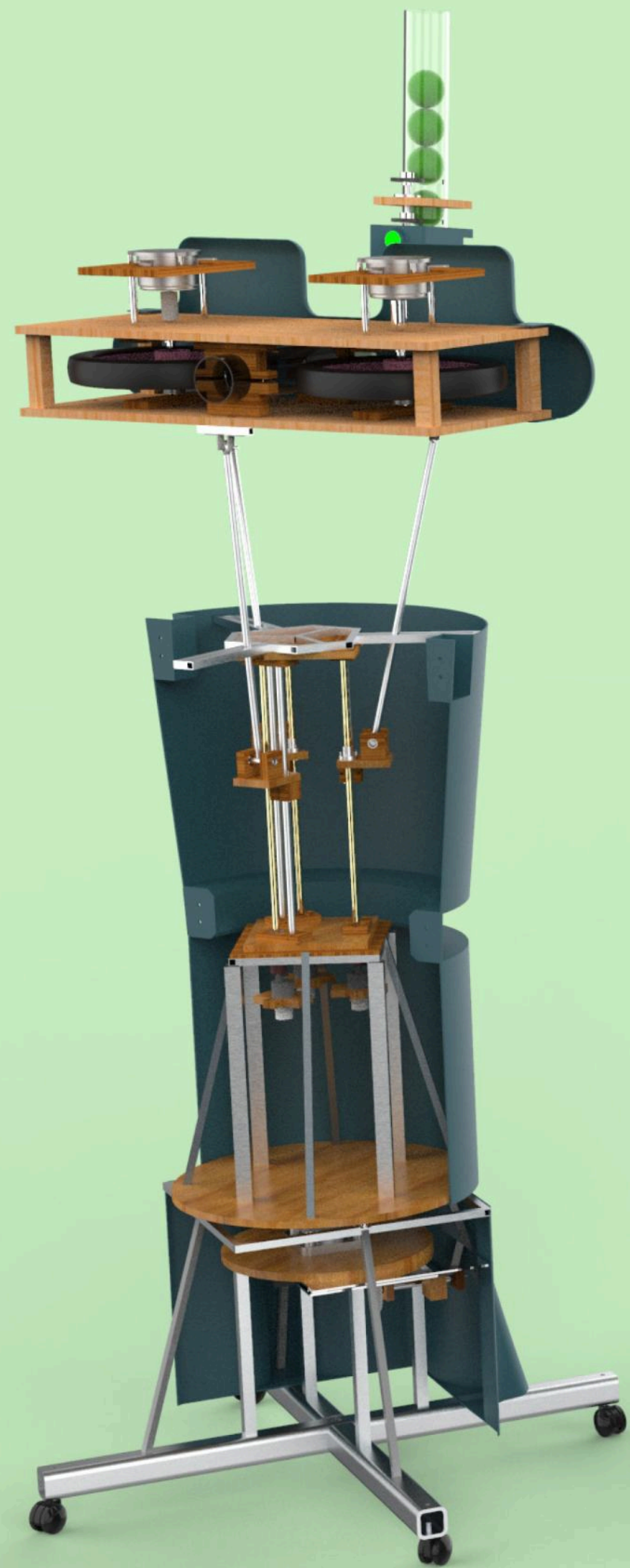

Ball Dispenser

Stores per over balls and allows one ball at a time through the shooting mechanism.

Shooting Mechanism

Shoots balls at a specific speed and swing/spin depending on wheels' velocity.

Angling Mechanism

Provides 1 translational(height) and 2 rotational degrees of freedom(roll & pitch) determining the length of the delivery.

Turntable Mechanism

Turntable provides 1 rotational degree of freedom(yaw) to determine line.

The design was prototyped and validated through real-world testing, successfully achieving full delivery variations and pace bowling speeds of up to 140 km/h; key mechanisms and components are detailed below.



Shooting wheel and flex coupled motor

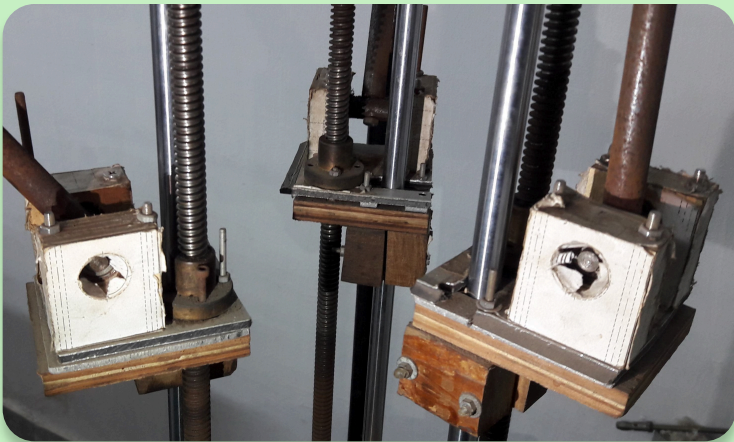

Linear actuators with lead screw & linear guides



Motor mounts

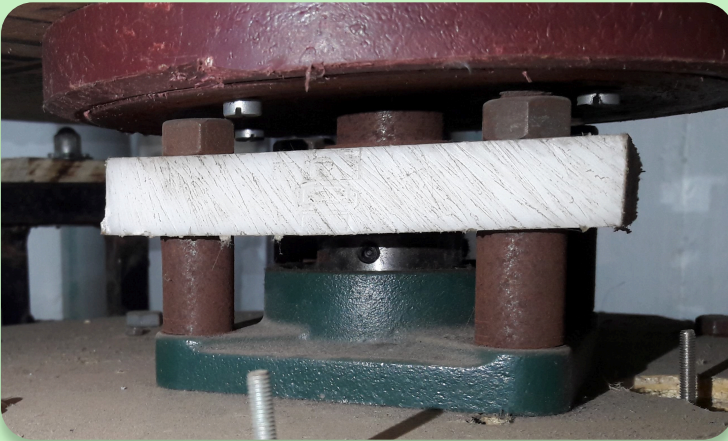

Plummer block bearing



Rack & pinion Gearing mechanism

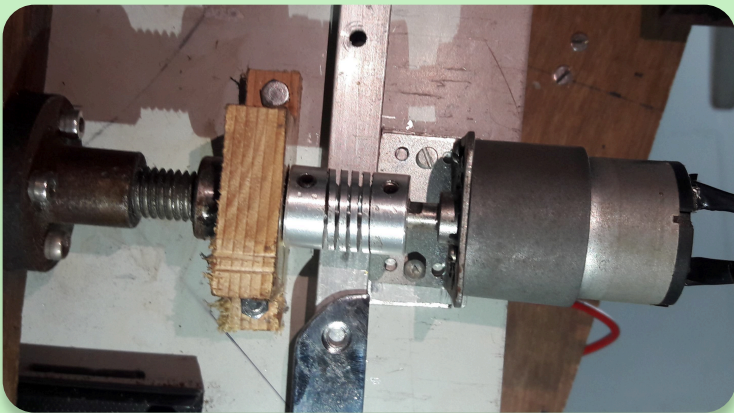

Motor mount

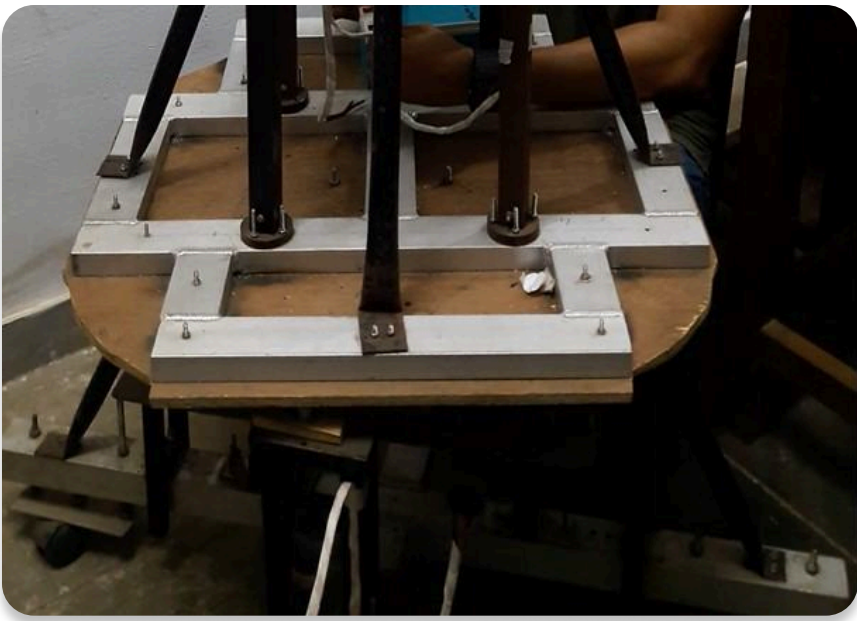
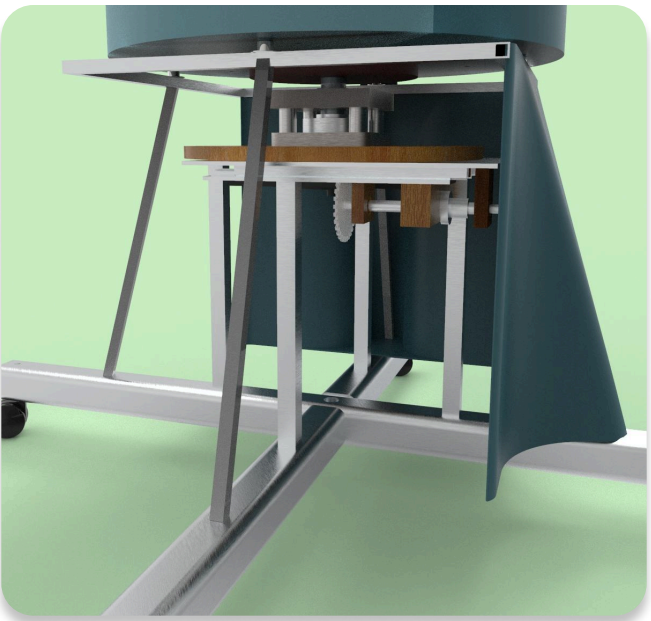
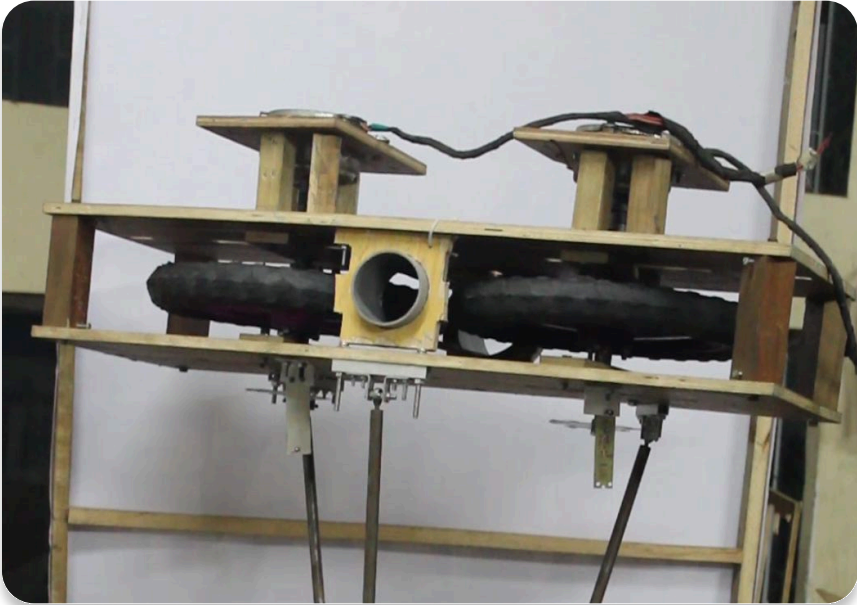
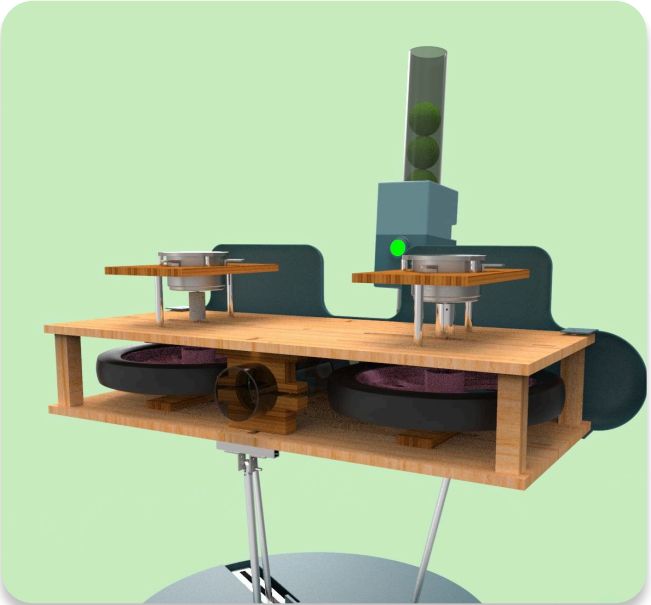



DESIGN & RESEARCH

Academic projects exploring product innovation through strategic research, market and trend analysis, concept development, prototyping, and thesis-driven design innovation.

 Student of MSc Integrated Product Design

 Delft University of Technology, Netherlands

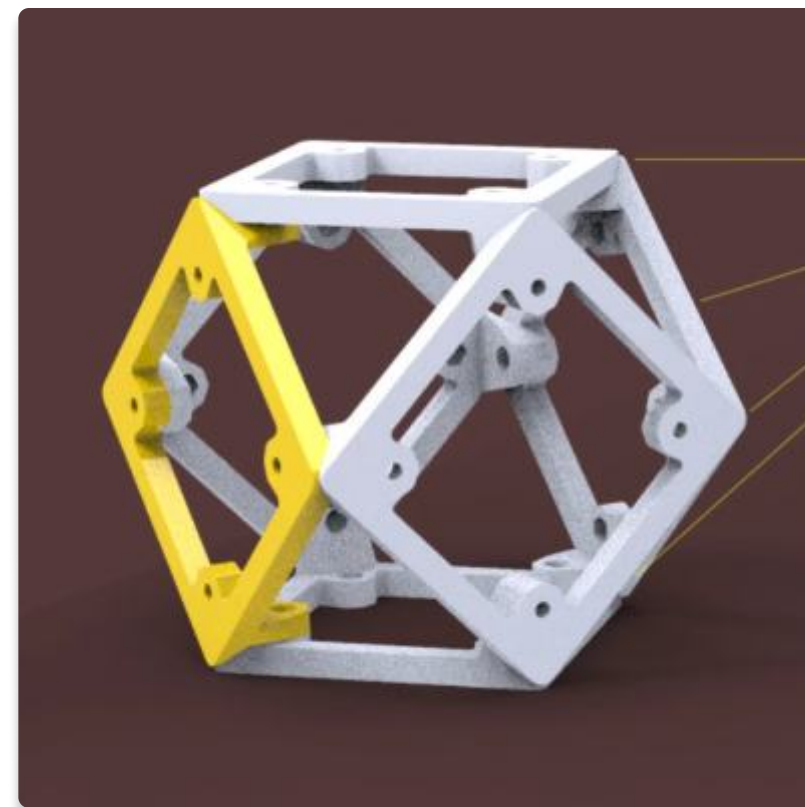

Modularity in lattice structures
for Circular Product Design

 Jan - June 2022

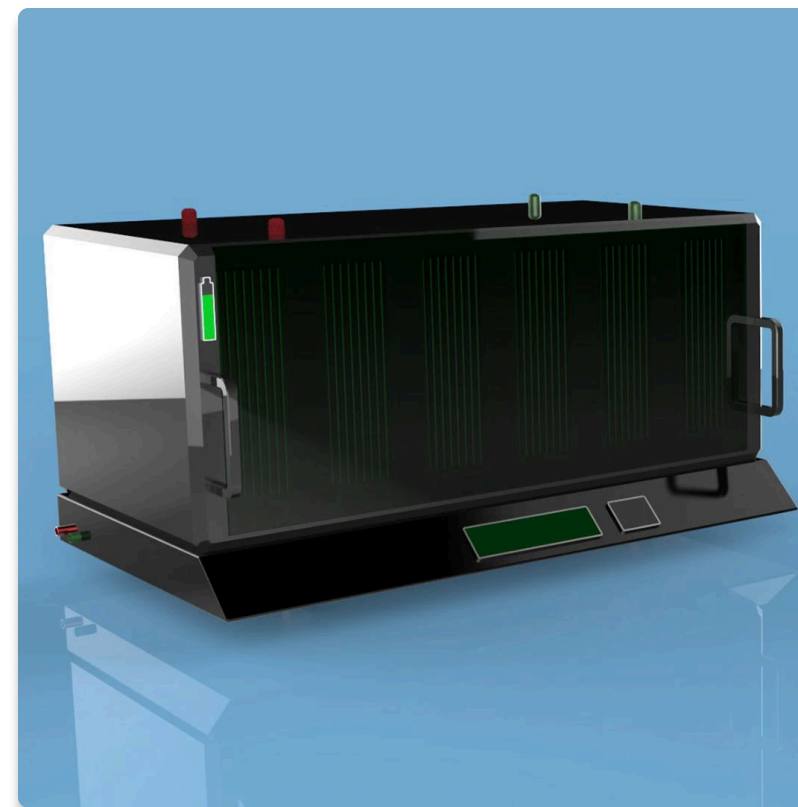

Prometheus — Sustainable
Future for EV Battery Lifecycles

 Nov - Dec 2019



AXA (Allegion plc) Bike Locks -
Future Mobility Strategy

 Sept - Oct 2019

Modularity in Lattice Structures for Circular Product Design

Master's thesis at Delft University of Technology exploring modularity in lattice structures for reparability and reuse, with a focus on efficient manufacturing of parametric modular lattices through subtractive processes.

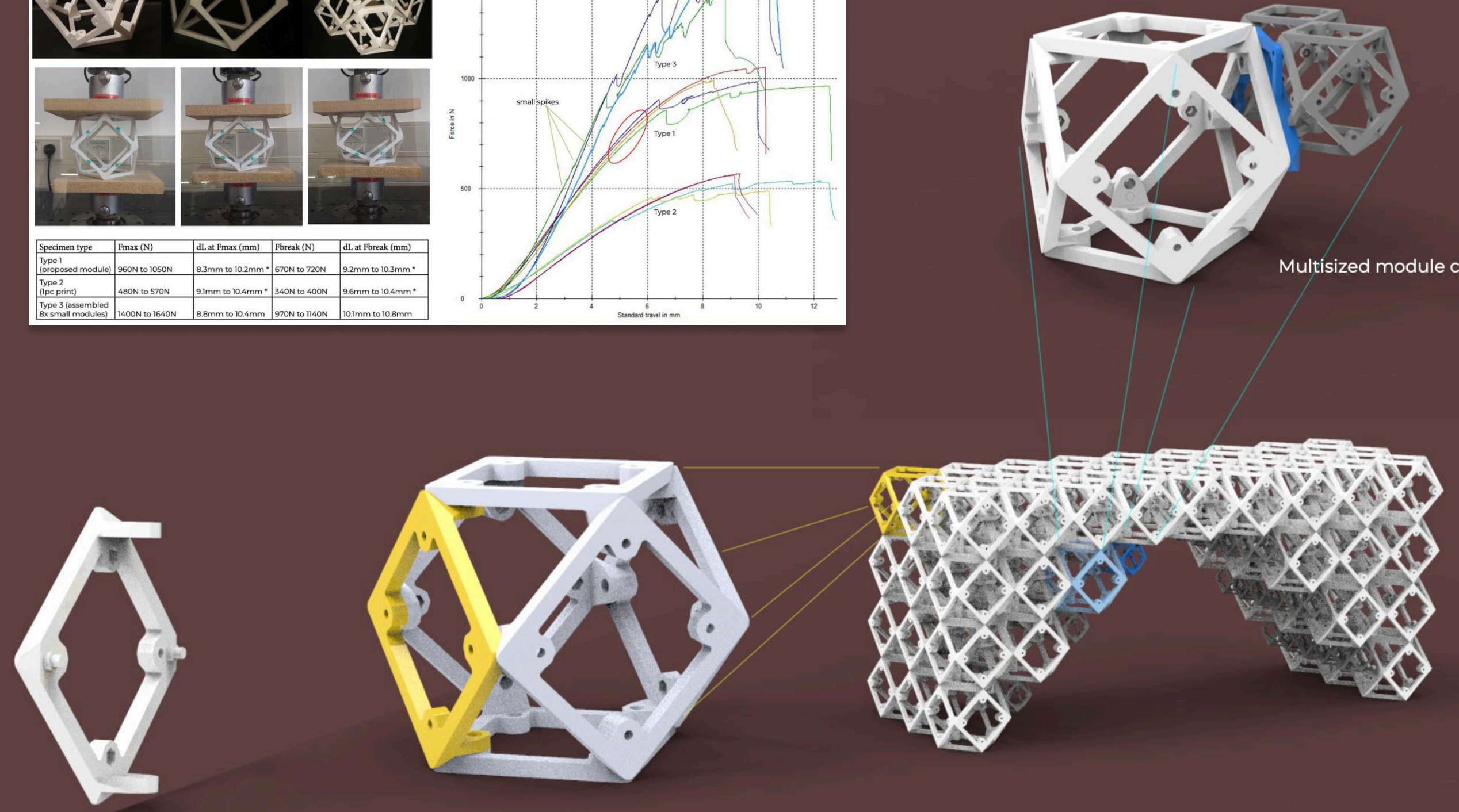
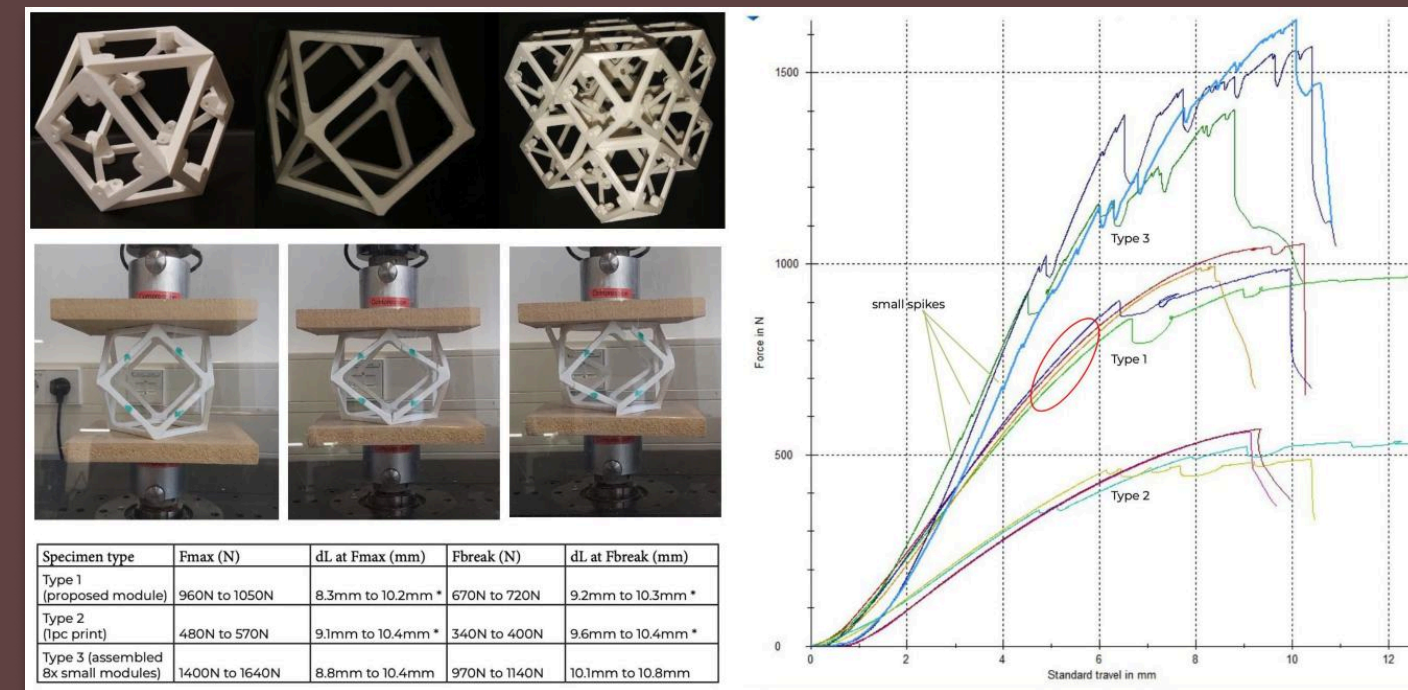
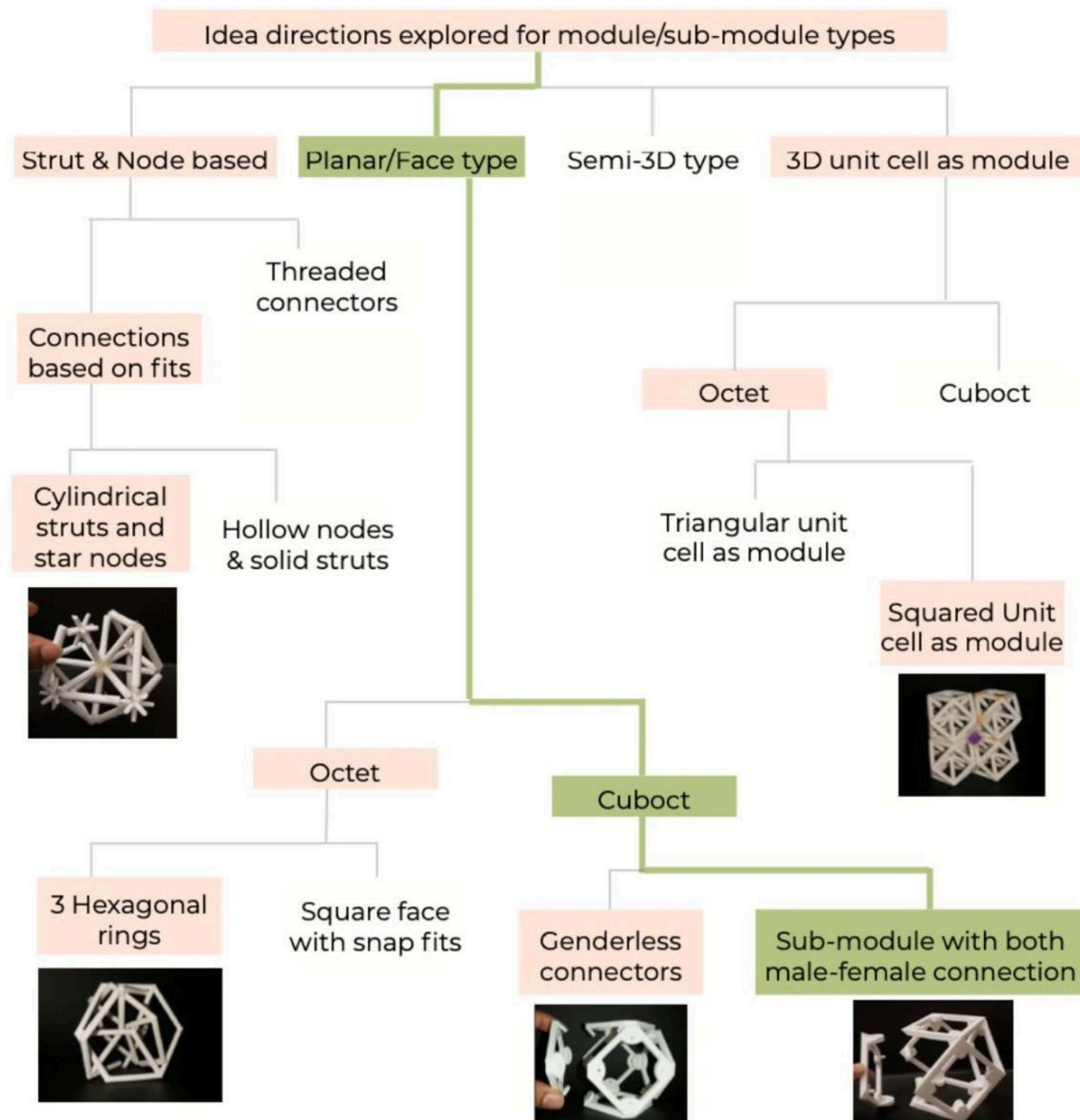
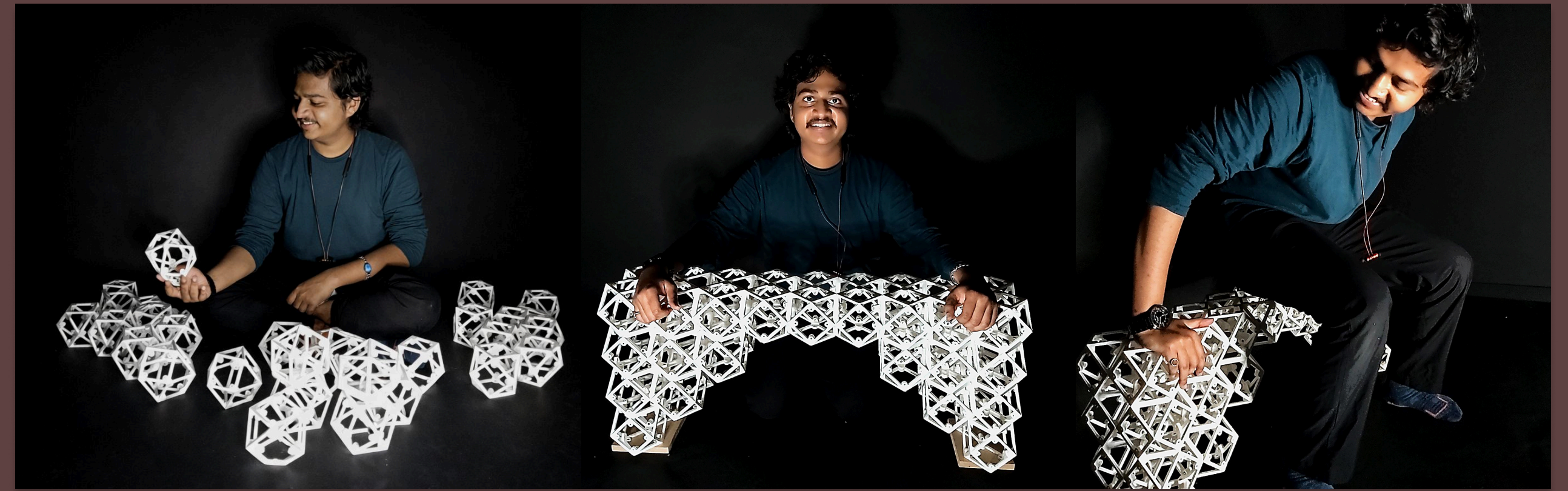

PROMETHEUS

Strategic design research assessing the true environmental break-even of EVs v/s combustion vehicles, while exploring circular economy approaches through battery repurposing before recycling.

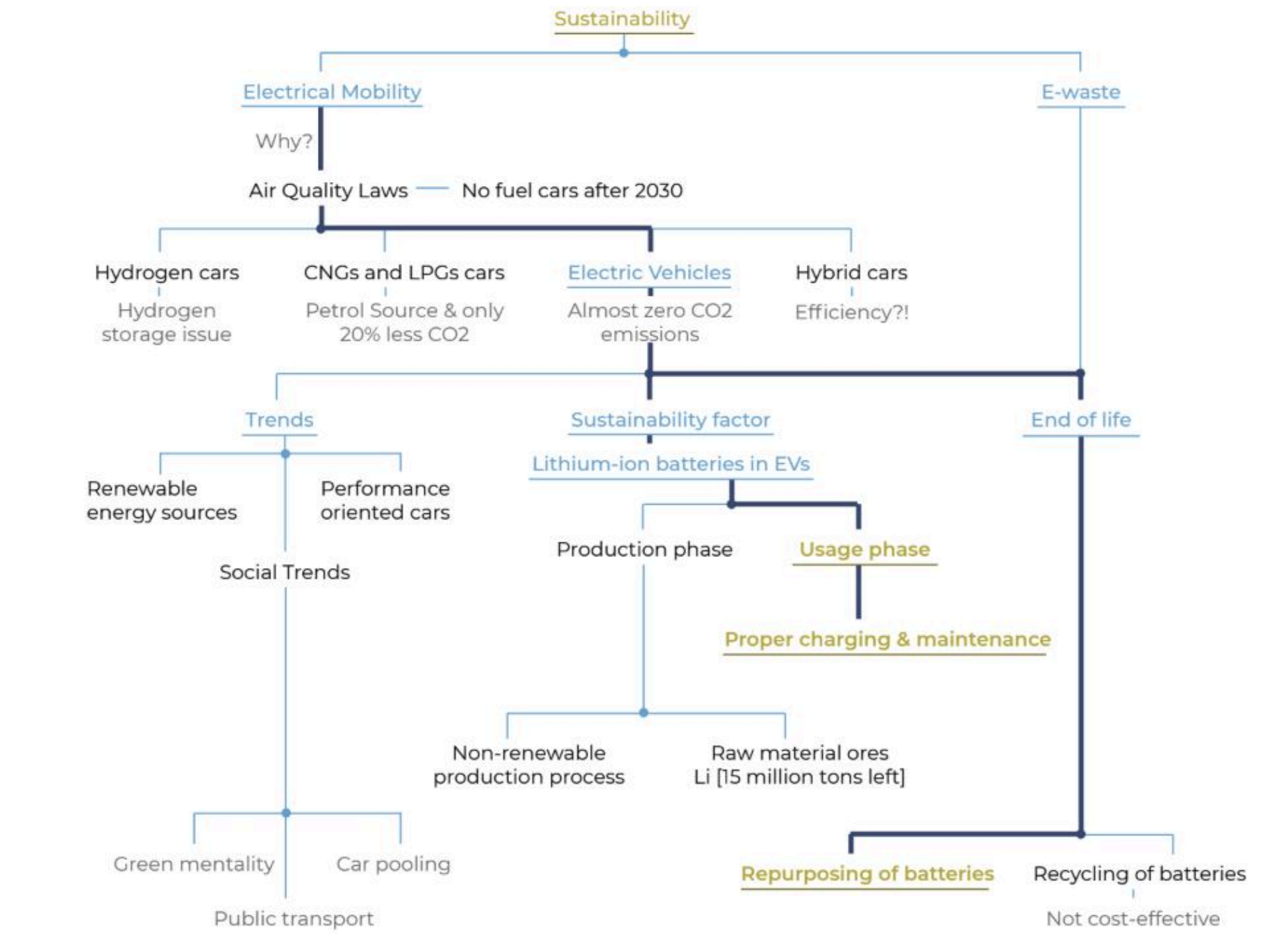
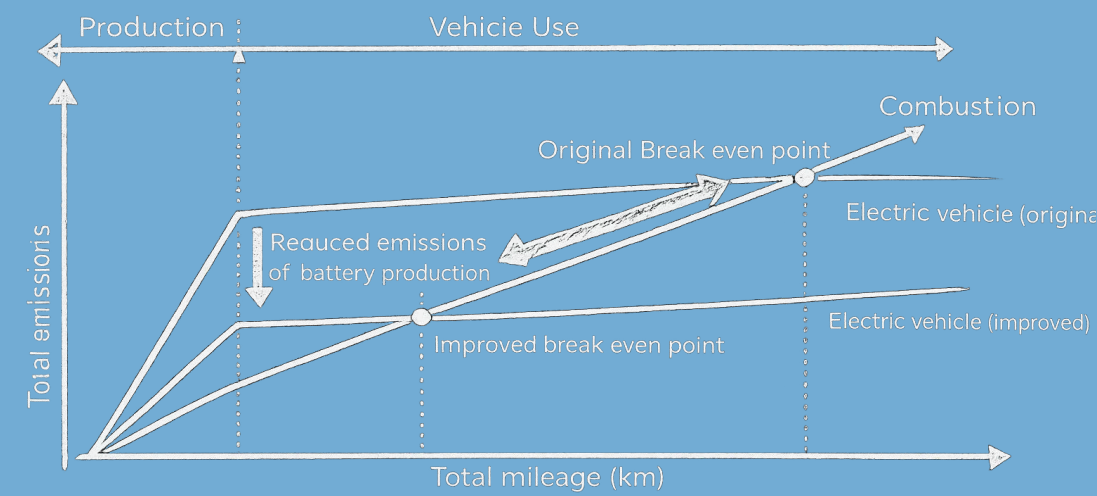

SERVICE BLUEPRINT

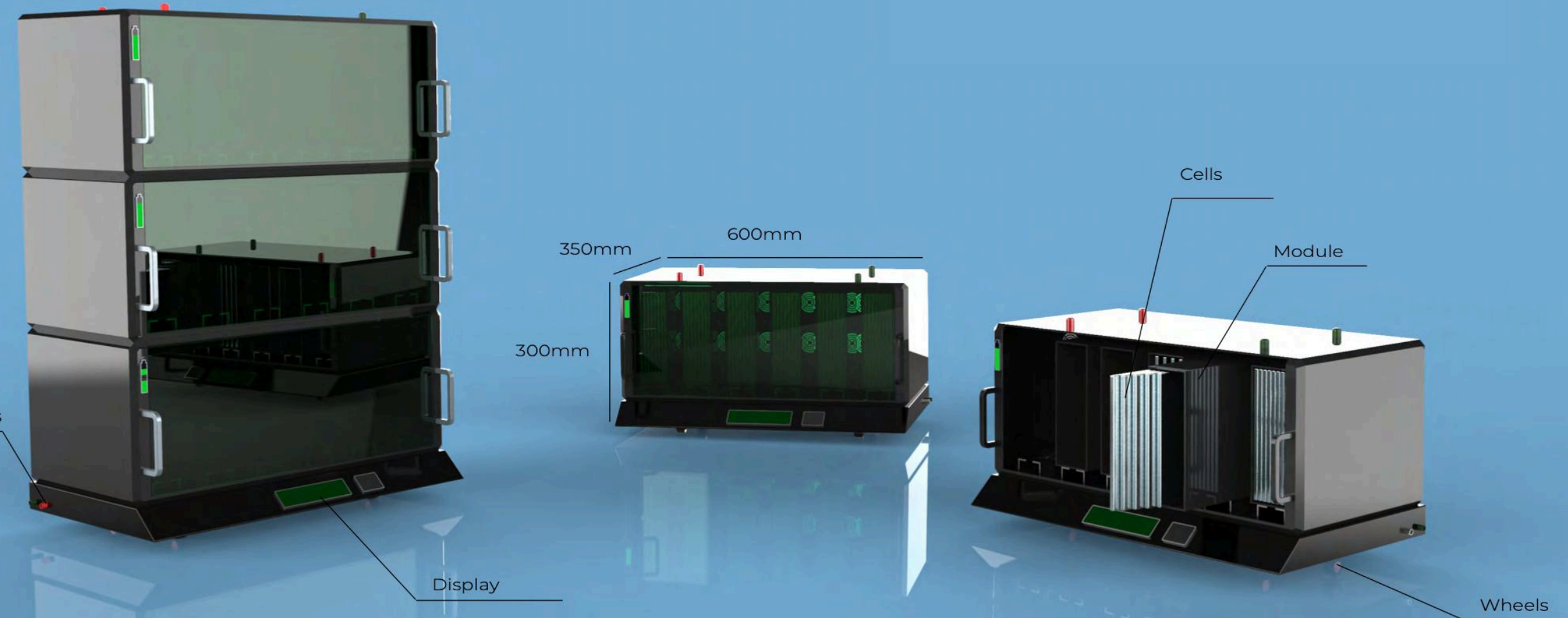
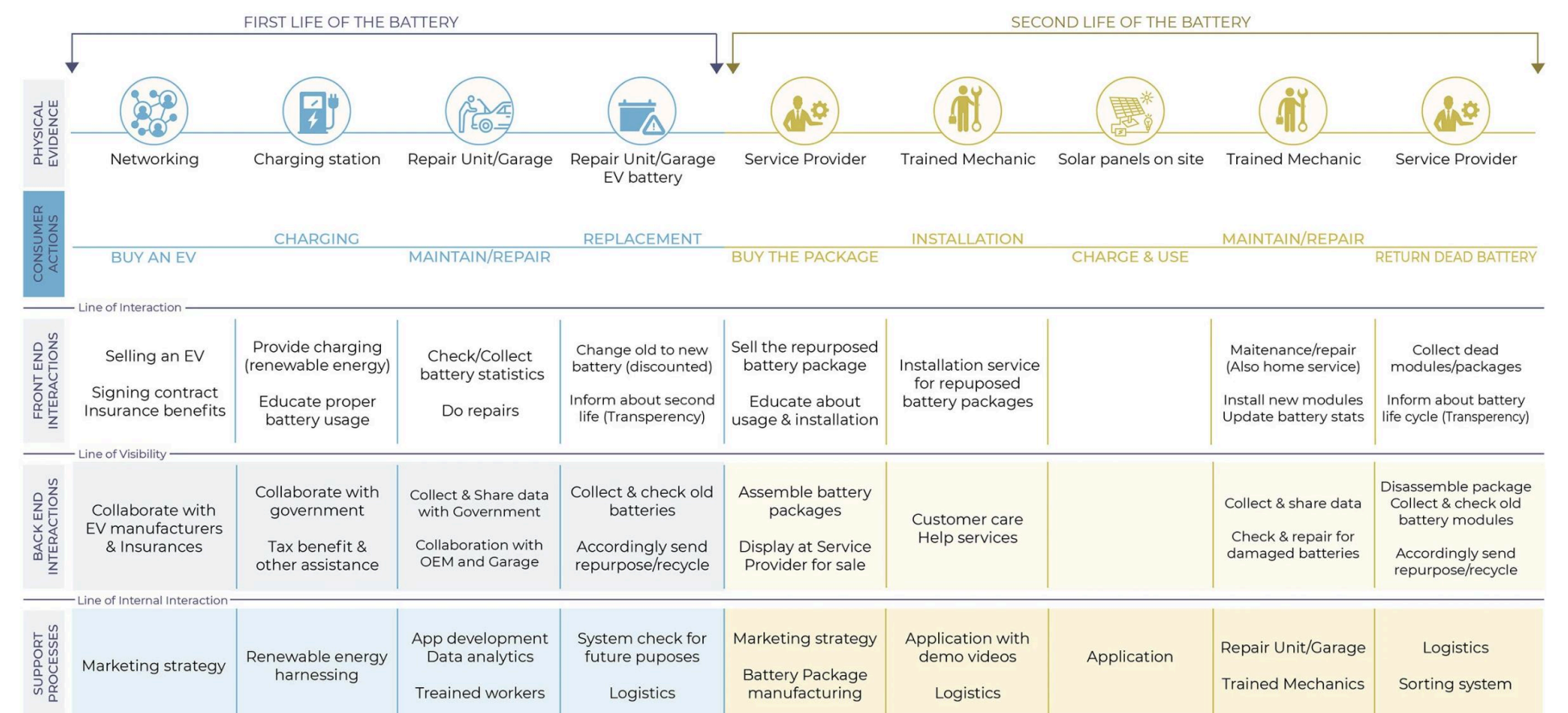

Strategic design project for AXA (Allegion plc) exploring smart bike parking solutions, resulting in a service design proposal, smart lock product concept, functional prototype, and mobile application interface.



INTERNAL ANALYSIS

Production Facilities



Finances

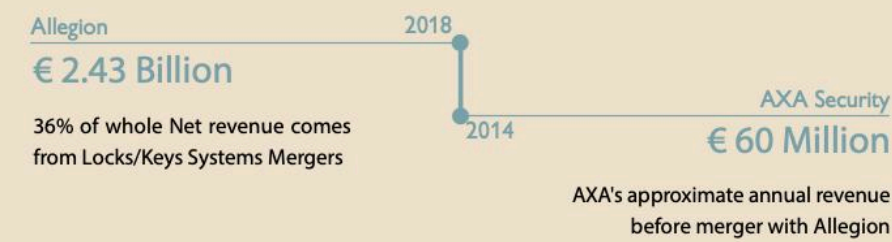

TREND ANALYSIS

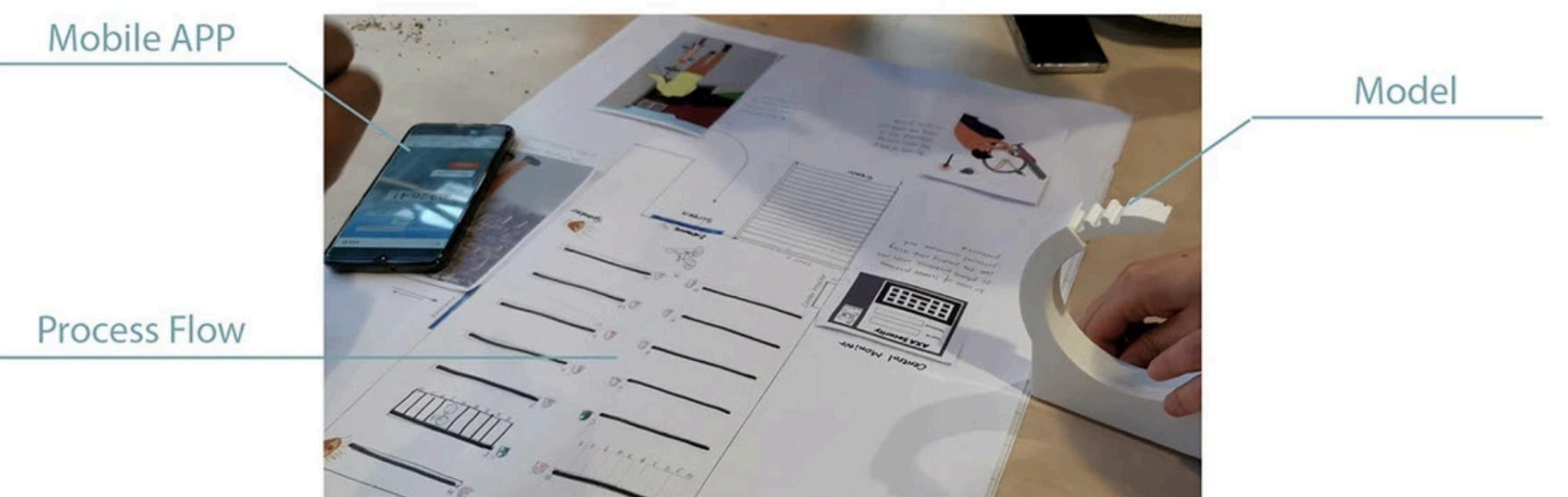
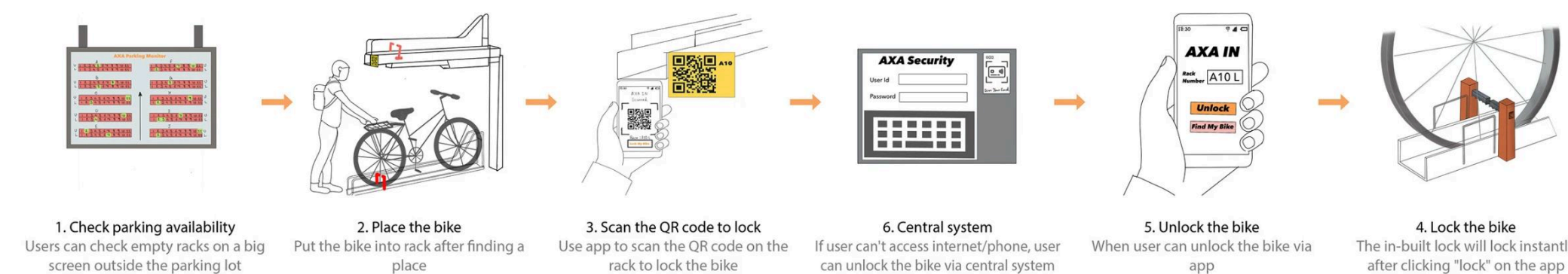
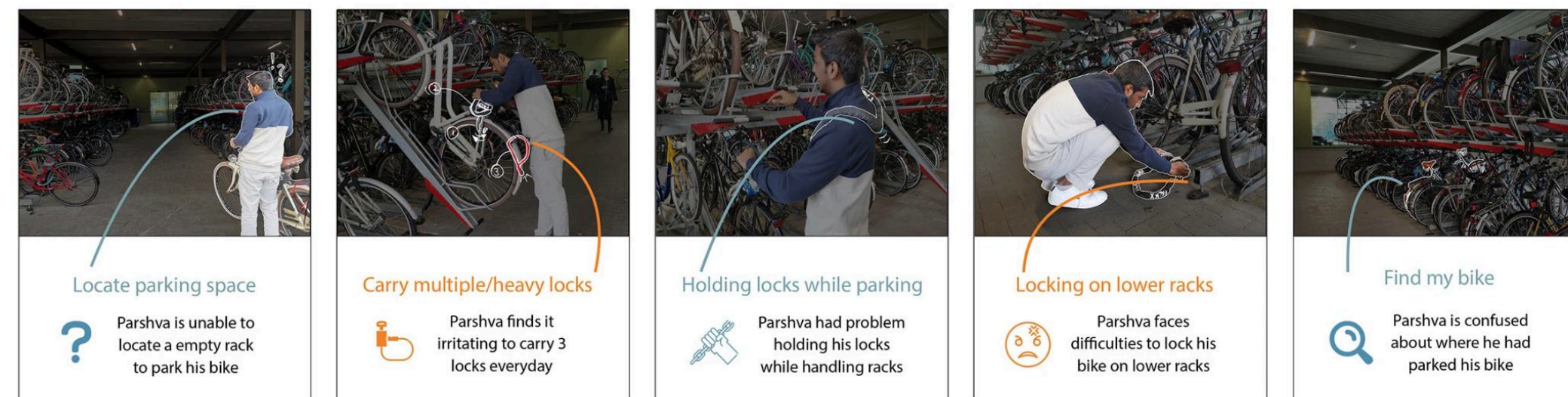

Scenario 1: Concept Explanation



Scenario 2: Model Demonstration



Scenario 3: App Interface Experience



FAB ACADEMY | Instructor & Node Manager

Served as Node Manager and Instructor for the Fab Academy program (Fab Foundation, MIT, USA) at the riidl Mumbai node (2023–2026), delivering training in digital fabrication including electronics design, CAD/CAM, 3D printing, and networking systems.



GUEST LECTURER | Design, Engineering, and Entrepreneurship

Served as Guest Lecturer and Visiting Faculty across institutes including Somaiya School of Design, NMIMS, and Mumbai University colleges, delivering sessions on Design, Engineering, and Entrepreneurship.

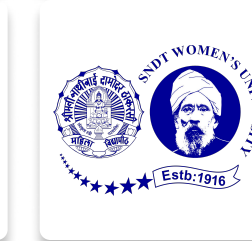

+ many more

Ready to build something meaningful, manufacturable, and scalable?
Have a problem worth solving but need the right design and engineering approach?

Let's

MAKE IT HAPPEN



Pranav Gawde

+91 7718961063

gawde.design@gmail.com

pranavgawde.in